

Monadology, Information, and Physics

Part 2: Space and Time (revised)

Soshichi Uchii
(Kyoto University, Emeritus)

Abstract

In Part 2, drawing on the results of Part 1, I will present my own interpretation of Leibniz's philosophy of space and time. As regards Leibniz's theory of geometry (*Analysis Situs*) and space, De Risi's excellent work appeared in 2007, so I will depend on this work. However, he does not deal with Leibniz's view on time, and moreover, he seems to misunderstand the essential part of Leibniz's view on time. Therefore I will begin with Richard Arthur's paper (1985), and J. A. Cover's improvement (1997). Despite some valuable insights contained in their papers, I have to conclude their attempts fail in one way or another, because they disregard the *order* of state-transition of a monad, which is, on my view, one of the *essential* features of the monads. By reexamining Leibniz's important text *Initia Rerum* (1714), I arrived at the following interpretation. (1) Since the realm of monads is *timeless*, the order of state-transition of a monad provides only the *basis* of time in phenomena. (2) What Leibniz calls "simultaneity" should be understood in two, related ways, first as (a) a timeless 1-to-1 correspondence of the states of different monads, and second (b) as temporal simultaneity definable on that basis. (3) With this understanding, whatever is correct in Arthur's and Cover's interpretation can be reproduced in my interpretation. On this basis, (4) we can introduce a *metric* of time based on *congruence of duration*. (5) Leibniz connected time with space in *Initia Rerum* by means of motion, and introduced the notion of *path* (which is spatial) of a moving point; thus the congruence of duration can be *reduced* to congruence of distance. (6) Then, I can show both *classical metric* and *relativistic metric* can be reconstructed on the *same basis*, depending on the *coding* for phenomena. (7) The relativistic metric can be combined with Leibniz's idea of *internal living force*, suggesting a relation of mass with energy. (8) However, since Leibniz has never shown the ground of *constant speed* of an inertial motion, there may be a vicious circle. (9) In order to avoid this, we can extend the notion of *path* to whole *situation*, thus yielding a *trajectory* of the whole phenomenal world. (10) Then, by applying optimality to possible paths, we may arrive at the law of motion, without vicious circle. A comparison of Leibniz's dynamics with Barbour's concludes Part 2. A Synopsis is added.

* * * * *

Synopsis of Part 2: Space and Time

16. Space and *Analysis Situs* (Figure 8: Relational Place, Figure 9: Interval and Metric)

- De Risi's work on *Analysis Situs* / Metric and geometrical quantity / Time is different from space
17. From Situation to Space
Space according to *Analysis Situs*
 18. How can Time be joined to Space?
Analogy between time and space / Order of succession is the basis of time
 19. Arthur on Leibniz's Time
Significance of *Initia Rerum*, Double Interpretation / Arthur's reconstruction / Arthur neglected order of states
 20. J. A. Cover's Improvement?
Cover introduced "world-state" / But neglected order again
 21. A Finite Model of Monads (Figure 10: A Finite Model with 4 Monads)
My reconstruction illustrated by a model / My model preserves order / Points out a hidden premise
 22. Extensions to the Infinite Case (Figure 11: World-States by 1-to-1 Correspondence, Figure 12: Alignment of States between two Continua)
Countable case / Continuous case
 23. Summary of my Interpretation of Leibniz's Basis of Time
Leibniz's view as regards the basis of time / Activities and changes in the timeless world
 24. Metric Time in Phenomena
Leibniz on magnitude of time / Time can be reduced to space via motion / The path of motion can be perceived simultaneously / Minimal path and straight line
 25. How to introduce Temporal Congruence? (Figure 13: Inertial Motion and Unit Time, Figure 14: Proportion of Two Speeds)
Assuming inertial motion, temporal congruence can be defined / But uniformity is presupposed
 26. Relativity of Motion and Simultaneity
Simultaneity in the phenomenal world / Two possibilities, Classical and relativistic
 27. Classical Time in Leibniz's Dynamics
Order of succession in the monads can be transformed to metric time in classical way / Metric is produced via coding for phenomena
 28. Relativistic Metric in Leibniz (Figure 15: Bi-metric Relativity for Humans and Angels)
Relativistic metric is also possible with no change in Leibniz's metaphysics / Moreover, even a bi-metric system is possible on the same basis / Leibniz's demon is possible even with relativistic metric
 29. Mass and Energy

The relation of mass and energy can be incorporated in Leibniz's dynamics, in conformity with his notion of partial living force

30. What is the Problem with Inertia and Relativity? (Figure 16: Can Relativity be Generalized?)

Leibniz did not discuss the foundation of the law of inertia / Law of inertia inconsistent with wholesale relativity

31. How can Leibniz establish the Law of Inertia?

Leibniz's last research on *Analysis Situs* shows he is still ambivalent as regards his definition of straight line / But the notion of path can be extended to the whole situation / Why not apply optimality to paths?

Appendix to Section 31: Barbour's *Platonica* and *Shape Space* (Figure 17: A Configuration Space, Figure 18: *Platonica* for Possible Triangles, Figure 19: Two Representations of Planetary Motion, Figure 20: *Shape Space* and the Planetary Motion)

Barbour's relational dynamics has many things in common with Leibniz's dynamics

* * * * *

16. Space and *Analysis Situs*

We have seen the internal structure of Leibniz's theories of metaphysics and dynamics. We will now examine the scope of his dynamics. In Section 8, I have suggested that Leibniz's view of total and partial living force of a body may have some connection with Einstein's special relativity. But, of course, in order to discuss this problem, we have to refer to Leibniz's view on space and time. (If the reader wishes to read a much shorter version of this Part 2, mainly concentrating on Leibniz's theory of time, see Uchii 2015a.)

Let us begin with the problem of space. Space is naturally related with geometry; hence we have to refer to Leibniz's ideas in geometry too. Recently I was very much impressed by De Risi's book (2007) on Leibniz's geometry, *Analysis Situs*. This is an outstanding work in its own right, and this helped me a great deal for improving my interpretation of Leibniz's view on space and time. I have been puzzled by his word "situation" in his correspondence with Samuel Clarke, when he discussed the problem of space. But now it is clear that Leibniz used this word on the basis of his *Analysis Situs* (analysis of *situation*). Let me quote from De Risi (2007, 129):

For present purposes, it is at least worth mentioning that in the *analysis situs* we first find definitions and theorems the object of which is *space* in general.

Now, this is a truly remarkable innovation, for no definition of space can be found in Euclid's work or, as a rule, in any geometrical treatise prior to modern times.

Indeed, read section 47 of the 5th Paper, *Leibniz-Clarke Correspondence* (Alexander 1956, 70). Here, Leibniz begins to state his view on space, starting from "an order of co-existence," and this order is said to be the "situation" holding among those coexisting objects. Then, he introduces the notion of "place" as follows:

When it happens that one of those co-existent things changes its relation to a multitude of others, which do not change their relation among themselves; and that another thing, newly come, acquires the same relation to the others, as the former had; we then say, it is come into the place of the former; ...

This quotation must be understood with the following Figure 8 (illustrating what Leibniz writes in the same section) in mind. The point is, those objects (dark C, E, F, G, etc. in the Figure) which are "fixed," are made a "surrogate" of the reference frame. Double arrows in the Figure signify a "relation," which, together with other similar relations, makes up a situation. Notice that, since each of these objects (in the actual phenomena) corresponds (respectively) to a group of monads in reality, a situation represents some feature of reality.

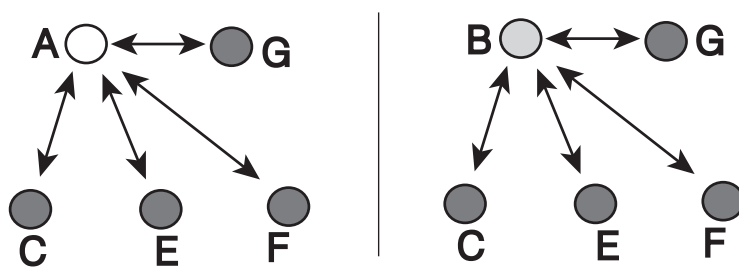

A and B are in the same place

Figure 8: Relational Place

Now, Leibniz, after explaining what place is, as in Figure 8, gives a brief definition of space: "Lastly, *space* is that which results from places taken together" (Alexander 1956, 70). In short, space is a collection of all places. Although it may be hard for the reader to fill in the details of Leibniz's construction of *space* in terms of *relational* concepts, at least the following should be clear: space is *ideal*, since all relations are ideal, not real for Leibniz. Thus he refuses Newton's absolute space, which is supposed to be *existing independently* from matter.

However, as De Risi points out, we can find no definition of “situation” (and that’s the reason why the reader is puzzled). But it may be reasonably guessed that Leibniz means something like a “set of relations holding among those objects” (“relations” of distance and relative directions, say). Something like an explanation can be found in “The Metaphysical Foundations of Mathematics” (1714, Loemker 1969, 671):

Situs is a certain relationship of coexistence between a plurality of entities; it is known by going back to other coexisting things which serve as intermediaries, that is, which have a simpler relation of coexistence to the original things.

Now, what we have to notice is that the previous characterization of “place” is not direct, but *via* the “same relation.” Towards the end of the same section of the 5th letter to Clarke, Leibniz explicitly states:

in order to explain what *place* is, I have been content to define what is the *same place*.

As De Risi has made abundantly clear, Leibniz’s geometry of situation depends on the notion of *congruence*. Two segments of lines, e.g., are congruent if they can be brought to *coincide* to each other; likewise for any two-dimensional figures like triangles, and for any three-dimensional objects such as cubes or spheres (in this case, we cannot make two objects coincide, so that we have to compare two figures and measure their size). We can easily see that this presupposes that we can *measure* the distance between two points. But how is the *magnitude* (quantity) of distance determined? By *repeated* use of a unit rod? Leibniz sometimes suggests this (each use is congruent). But this presupposes that the length of the rod does not change, depending on places (and mathematicians in the 19th century began to discuss such problems). As we will see shortly, Leibniz began to discuss several *features* of space.

Here, we have to be a bit careful. According to our differential geometry, the interval (distance) between two points depends on *metric*, which, given the difference of two *coordinate* values, transforms it to a definite *quantity*. Thus, if we take a two-dimensional coordinate system, the interval is determined as in Figure 9.

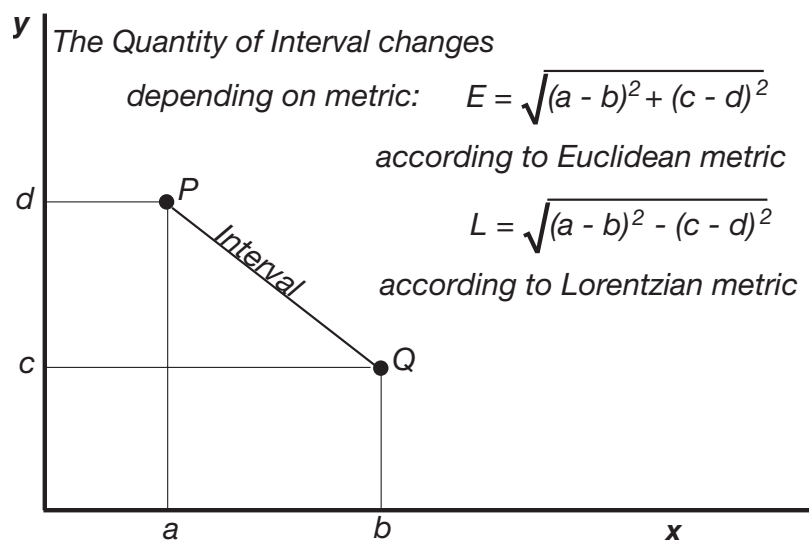

Figure 9: Interval and Metric

Suppose two points P and Q are given in a 2-dimensional coordinate system, and we wish to determine the interval between the two. According to the usual Euclidean geometry, the interval is called “distance,” and its metric is determined by the Pythagorean theorem, so that the distance is E in the Figure. However, if the coordinate system is interpreted as a Minkowski space of special relativity (y is then *time* measured by the velocity of light), the interval is determined by the Lorentz metric, so that its relation to coordinate values are completely different. These equations for metric may be more conveniently written in terms of a “squared” form such as the following:

$$(1) E^2 = (a - b)^2 + (c - d)^2$$

$$(2) L^2 = (a - b)^2 - (c - d)^2$$

I inserted this Figure, *solely* in order to remind the reader of the relation between a geometrical quantity and its *suppressed assumption*, i.e., metric. I have *no intention whatsoever* to suggest that Leibniz himself was aware of such a relation. Indeed, as De Risi repeatedly says, Leibniz was trying to *avoid* any analytical mathematics in order to develop his *Analysis Situs*. Thus, although he adopted *congruence* as a primary means for constructing his geometrical system, this merely means that *metric is arbitrary*, despite the fact that distance depends on some metric (according to our modern knowledge). And *this* is one of the most important features of his new geometry of situation, making it a *qualitative* study of geometry.

We also have to be careful as regards the difference between space and time. Space is “the order of possible coexistents” and time is “the order of possible inconsistencies,” according to Leibniz (see, e.g., the letter to de Volder, 31 Dec. 1700,

Gerhardt vol. 2, 221). Although two incompatible things cannot exist simultaneously (at the same moment), these incompatible things may occur at *different* moments of time. Thus, since any situation can hold *only* among those things existing *simultaneously*, we cannot talk about any situation among those things which occur *successively*.

We can derive at least two consequences from this: (i) Leibniz's *Analysis Situs* cannot be applied to motions, which need both space and *time*. (ii) If we want to talk about *metric*, metric of space and metric of time must be distinguished, and these must be treated independently. However, at the same time, we have to keep in mind the close connection of motion with situation, i.e., any motion is nothing but a *change of situation* (we saw this in Part 1, Section 4, Figure 1). Leibniz's own clear statement on this: "Motion is change of situation. We say that *a thing is moved* if there is in it a change of situs and at the same time a reason for this change" (Loemker 1969, 668). And Leibniz himself clearly stated that physics depends on geometry (quotation in Section 4). On the basis of these observations, I will later discuss the problem of time, but even at this stage, it is clear that we need *metric, via coding*, for time too.

17. From Situation to Space

Getting back to De Risi's work, let us briefly review Leibniz's final position (before his death) as regards space. De Risi has dug into unpublished manuscripts of Leibniz, and found that Leibniz was working on *Analysis Situs* until his death (1716). This means that Leibniz's letters to Clarke were written with his view on geometry of situation and its results. According to De Risi, Leibniz (in his old age) define "space as the locus of all loci, or better, of all points" (De Risi 2007, 167; "the locus of all loci" means "the place of all places"), and this corresponds to Leibniz's statement in the 5th paper to Clarke (Section 16). However, this definition must be understood with the following proviso: this does *not* mean space is *composed of* points, since the "point" here corresponds to "place" in the preceding quotation from Leibniz (Section 16). Leibniz now uses "point" as a bearer of *relations* (together with other points), but *unextended*. That is to say, "point" here means *locus* which is *unextended* (hence called "point") but *situated* (i.e., in a situation). As De Risi nicely summarizes, "Space turns out for him to be a set of relations between unextended (but situated) elements" (De Risi 2007, 174). In other words, space is *constituted by*, not composed of, places (loci as points), as Leibniz sometimes say (De Risi 2007, 173-4).

De Risi points out: If we think a set of points as a "purely quantitative collection," it can never produce extension; but if the set is such that its members are *terms of relations*, then these relations can produce a *structure*, and extension can be produced, and metric can be given (De Risi 2007, 174). So it can be conjectured that when Leibniz gave a reply to Clarke in his 5th paper, although he did not say anything explicitly, what was in his mind was this definition of space as a structured set of points, *loci*.

You may just recall Figure 8 of Section 16. Relations expressed by arrowed lines, or rather a network of such arrowed lines, does produce a structure among places (this time, *points*, rather than extended circles, should be used). When Leibniz wants to talk about the *totality* of places (points), he uses the word "absolute space," but its meaning is entirely different from the Newtonian absolute space, which is used as an absolute *frame of reference*.

Although De Risi's examination of *Analysis Situs*, and of the Leibnizian space thus defined, continues in detail, discussing such features of space, as *metric*, *uniformity* (*isotropy*), *curvature*, *continuity*, *homogeneity*, *tridimensionality*, etc. we will refrain from following it, since our main interests are in the connection of dynamics with space and time. Suffice it to say that the Leibnizian space is meant to be, according

to De Risi, isotropic, with a constant curvature, continuous, homogeneous, and tridimensional, although Leibniz has not necessarily succeeded in showing all these (De Risi 2007, 176-210); but Euclid geometry is obviously included in the candidates for geometry of the actual (phenomenal) world. Anyway, since dynamics needs time in addition to space, we are eager to get into the problem of *time*. How should we interpret Leibniz's treatment time?

18. How can Time be joined to Space?

In the “Addition” attached to Chapter 2, De Risi aptly refers to the problem of *motion*; and obviously, motion seems to presuppose *time*. He now raises a question: how can we extend, or apply *Analysis Situs* to the problem of motion and time (De Risi 2007, 266)? Here, I have to begin to disagree with many of what he says on *motion* and *time*, and further, on the *perceptions* and *appetites* of a monad.

De Risi seems to be generally unsympathetic to Leibniz’s treatment of time. And I suspect that the main reason is that he *misunderstood* the nature of monad, its *informational* character, as I would say. Let me point out several good evidences for alleging this “misunderstanding.” When he begins to discuss time, he writes as follows:

Temporal structure is often presented by Leibniz in a way analogous and specular to that of space. We will most naturally ask ourselves whether and to what extent situational analysis may be applied to time. (De Risi 2007, 270)

But this idea of asking “whether and to what extent situational analysis may be applied to time,” is *misguided* in the first place! As I have already pointed out in Section 16, we have to be careful as regards the *difference* between space and time. To put it bluntly, situational analysis *cannot* be applied to time, since any situation holds *only for* objects existing *simultaneously*. As Leibniz repeats many, many times, time is an order of succession; in other words, an order of *succession of situations* (or *configurations of bodies*). I may mention, in passing, that we can find a contemporary physicist who supports a similar view (see Barbour 2000, ch. 3; he is renowned as a physicist-philosopher who denies the existence of time. Moreover, his proposal of *timeless* physics has strong affinity with Leibnizian dynamics.)

Further, in the next paragraph (De Risi 2007, 271), De Risi contends as follows:

The main difficulty lies in that Leibniz never determines the principle according to which a temporal series may be ordered.

Again, this is a very strange assertion, to say the least. For, as we have already seen in this paper (Part 1), any temporal series (in phenomena) *must* be based on the *succession of states* of all monads, and in each monad, the succession of its states is *completely* determined by its transition function, an *internal principle of change*.

It seems De Risi considers Leibniz is somehow *ambiguous* as to the nature of time, as the following quotation shows:

In most writings Leibniz seems to account for the passing of time by a change in monadic properties, thus *definitely assigning substances ... to the sphere of diachronic succession*. In other writings, especially his late ones, Leibniz seems on the contrary also to embrace a radical phenomenalism relative to time. Thus ... he seems to think that *monads are outside any temporal order, while only their phenomenal manifestations occur in time*. (De Risi 2007, 271, my italics)

I have italicized two parts in this quotation, (1) the former ascribing temporal changes to substances, (2) the latter denying such and regarding monadic changes as atemporal. And as far as Leibniz's metaphysics in his later period (i.e., the period he wrote *Monadology* and presented his mature view on *Analysis Situs*) is concerned, I think he holds *definitely the latter view* (2), as I have pointed out at the outset of this paper (Part 1). And although I do *not* think he embraced (1), even in the *Discourse on Metaphysics* (1686, before his informational turn), I will leave this matter for examination by other interpreters. Anyway, I think the preceding should be sufficient for alleging De Risi's *misunderstanding* as regards Leibniz's view on time.

As I have been insisting, a monad is governed by a transition function, and the whole of its sequence of states is determined by that function (as soon as it is created by God). This means that the order of succession of states in any monad, whether or not it is the dominant monad (*entelechy* or *anima*) of an organism, is *determined in reality* (without time, of course). And since, for any monad, the whole sequence of states (perceptions) is given *at once*, the reality is without time. However, since a transition function governs *changes* in a monad, there is of course an *order of states*, but this is *not* time. I myself once misunderstood "changes" Leibniz mentioned as implying "time"; but soon realized (thanks to Barbour's works) that we have to distinguish changes from *temporal changes*. This order of states implies a change, but it does not imply a temporal change; rather, this order should be considered as the *source of time* (in the phenomenal world). Briefly summarized, "only order in reality, time in phenomena"; this is my interpretation.

It may be helpful if you consider, as an analogy, the sequence of natural numbers. The members of this sequence are connected by the relation of "successor" so that the set of all natural numbers has certainly a structure created by this relation. And if we follow this sequence, there is a change at each step, i.e., the next number is *different* from the previous one; yet this change does not imply time at all! Likewise,

in the sequence of states of a monad, there are changes but these changes are not, by themselves, temporal changes; hence Leibniz does not presuppose time at all.

Now, recall that there is a basis of a phenomenal situation in reality. As De Risk emphasizes, a situation reflects some (qualitative) features holding in reality. However, since a metric is added (by God's coding together with the relation of congruence, I would say) in a phenomenal situation, a metric space becomes indispensable for our phenomenal world. In a quite analogous way, there is a definite basis, in reality, of time, and hence of motion (a change of situation) also, as we have argued in Part 1 (Sections 4-8). And the source of time is contained in each monad, as the internal principle of change (according to Leibniz's words), as the program (or transition function) of each monad (according to my own words).

Now, I can understand why De Risi felt uneasy about Leibniz's treatment of time. For, having nicely reconstructed Leibniz's view on space, including its metric character, from *Analysis Situs*, he failed to find an analogue for time because he was stuck to the notion of *situation*. But I am going to argue that we can *easily* find such an analogue. Recall that De Risi emphasized that "space is a set of relations between unextended (but situated) elements," and "space is *constituted by*, not composed of, places" (Section 17). We can repeat perfectly analogous statements as regards time: time is a set of relations between unextended elements which may be called *instants*, and these relations are nothing but *succession*, instead of situation; further, time is *constituted by*, not composed of, instants. As soon as a *metric* is assigned to the order of succession (by God's coding), this order turns into time in phenomena, and we can measure an interval (duration) of time.

Notice De Risi's following argument (De Risi 2007, 274), where we can clearly see that he was indeed *stuck to the notion of situation*:

the greatest effort Leibniz has made and the best result he has achieved in building his own theory of measure precisely consist in showing that the measure of a continuous quantum cannot arise from the numerosness of the points (or instants) that make it up, but it is, on the contrary, a specific function of the system of relations entertained between the elements of the continuum. It naturally follows that, in order to be a continuum liable to be measured, time must arise from situational relations.

I can agree with everything in this quotation, *except for* the last statement. And, if the last part is changed to "time must arise from the *relation of succession*," I can gladly agree! Then, of course, Leibniz's analogy between space and time holds

perfectly, although the two are different in their source and nature; and the *metric* of time arises from the relation of succession (together with God's coding and some criterion for determining the *identity of interval*), and time *must* be one-dimensional, because of this relation of succession. Since, on this point, Leibniz's following statement is relevant, let me quote it with insertions of the original Latin words:

I said that extension is the order of coexisting possibles, and that time is the order of inconsistent possibilities. If this is so, you say that it astonishes you how time is found in everything, both spiritual and corporeal, but extension is found only in bodies. I respond that the reason is the same in both cases and for both sorts of things, namely, for all changes, of both spiritual and material things, there is a place [*sedes*], so to speak, in the order of succession, that is, in time, and for all changes, of both spiritual and material things, there is a place [*locus*] in the order of coexistents, that is, in space. (20 June 1703, to de Volder, Ariew and Garber 1989, 178; Latin words in brackets inserted by me.)

If, instead of "extension," we replace "location," what Leibniz is saying here is that both material events and mental events have a *location*, as well as an *instant* of occurrence. This is what I said in Part 1, Section 1, (3). This shows Leibniz is quite confident of the analogy between space and time, despite the fact they differ in their source and nature. Hence, if Leibniz thought he obtained good results as regards space, he must have extended them to time too. After all, the structure of one-dimensional time is much simpler (although time itself is indeed a first-rate enigma).

Thus, in conclusion, metric time can be obtained by the same logic and mathematics in Leibniz's metaphysics, and quantitative motion becomes possible in phenomena, combining *situations* and *their changes through time*. I am really grateful for De Risi's valuable insight and help on this point. What we have to keep in mind is that the metric of space and the metric of time must be treated independently (because their source is obviously different), although there may arise some interconnection between the two, if we take dynamics into consideration.

In view of this conclusion, let me quote the paragraph (section) 105 of Leibniz's 5th paper to Clarke:

The author objects here, that time cannot be an order of successive things, because the quantity of time may become greater or less, and yet the order of successions continue the same. I answer; this is not so. For if the time is

greater, there will be more successive and like states interposed; and if it be less, there will be fewer; seeing there is no vacuum, nor condensation, or penetration, (if I may so speak), in times, any more than in places. (Leibniz's 5th Paper, Alexander 1956, 89-90)

When I first read this paragraph, I was disappointed; and I have been puzzled by this paragraph for a long time, because I have been unable to find the "hidden reasoning" behind it. But now, I think I have found Leibniz's reason for asserting this. He is clearly suggesting that he (or rather God) can produce a *continuum* of time (in *phenomena*, of course) from the order of successions (in *reality*), and give it a *metric*! Thus, just as matter and space are infinitely divisible, *time is also infinitely divisible*. Leibniz's reply to Clarke (the preceding quotation) implies this. And although I will continue to utilize our discrete model of state-transition (Part 1 Sect. 13) for a while, I am clearly aware that this is insufficient, because a monad undergoes a *continuous* state-transition. However, it will turn out later (Sect. 22) that most important features of our discrete model can be transferred to the continuous case.

However, before discussing this problem, we have to see Leibniz's *general* view on time. It seems many interpreters misunderstood Leibniz's view on time (as an example, I have pointed out De Risi's misunderstanding). And as far as I know, Richard Arthur, in his 1985 paper, first indicated the right way to interpret Leibniz's theory of time.

19. Arthur on Leibniz's Time

Richard Arthur, after examining and criticizing several interpretations of Leibniz's theory of time by such people as Russell, Rescher, McGuire, etc., begins his own interpretation, drawing on the text of "The Metaphysical Foundations of Mathematics" (*Initia Rerum Mathematicarum Metaphysica*, 1714, translated and included in Loemker 1969, 666-674. Henceforth *Initia Rerum*. The original Latin text is in Gerhardt, ed., *Leibnizens mathematische Schriften*, vol. 7, abbreviated as "Gerhardt M"). It is noteworthy that in this paper, Leibniz briefly explained *both* his geometry (*Analysis Situs*) and his view on time. Moreover, Leibniz eagerly repeats his analogical treatment of space and time. In order to examine Arthur's reconstruction of Leibniz's view on time, we have to keep in mind the overall structure of *Initia Rerum*, since we should not interpret Leibniz's statements out of his context.

Leibniz begins this paper with the following remarks: (i) "there is an art of analysis more inclusive than mathematics, from which mathematical science derives its most beautiful methods," and he reminds us that, (ii) for showing this, we need "somewhat higher order of principles" (Loemker 1969, 666). Thus it is clear he is seeking a *deeper foundation* of mathematics, including geometry and mathematical physics. Then, he begins to state his view on time, space, geometry (analysis situs), and motion.

This flow of argument strongly suggests that, although Leibniz refers to no concepts of *Monadology* in this paper, his argument is made in view of his metaphysics of monads, and that the "higher order of principles" mentioned above are connected with his metaphysics. Thus there is a good reason for supposing that he wrote this paper as a *link* between mathematics for dynamics and metaphysics of monads. And we have to keep in mind that Leibniz assumes there are various *homomorphisms* (partial isomorphisms) between the monadic realm and the phenomenal world.

With this preparation, let us proceed to Arthur's reconstruction. Arthur is concerned only with the part on time. And for a while we will follow his argument. He says that a formal reconstruction of Leibniz's view is useful:

By stating Leibniz's axioms and definitions in set-theoretic notation, it can be shown how both *instants* and *time* can be constructed on this basis without in any way presupposing that each monad has its own intra-monadic time. (Arthur 1985, 268)

On my view, this passage shows that Arthur himself still inherits some misunderstanding of those predecessors (whom he criticized), but his reconstruction of Leibniz's view is sometimes illuminating and touches on the essential point, that *the succession of states in each monad (i.e., the order of succession) does provide the basis for time in the phenomena* (this is not Arthur's own statement, but my own sympathetic reconstruction). As I have repeated many times in this paper, I think neither time nor temporal succession exists in the realm of monads; instead, only the *order* of succession (state-transition) is given. But for a while I will follow Arthur's discussion, allowing his terminology as it stands.

All right, then, what are the textual evidences on which Arthur relies for his interpretation? There are several, in Leibniz's paper mentioned above. Since these texts are important, I will quote both the original Latin texts and Loemker's translated texts.

- (1) Si plures ponantur existere rerum status, nihil oppositum involventes, dicentur existere **simul**. (Gerhardt M, vol.7, 18) *If a plurality of states of things is assumed to exist which involve no opposition to each other, they are said to exist simultaneously. (Initia Rerum, Loemker 1969, 666)*

Arthur (using his own translation from Latin) assumes that in this passage Leibniz is talking about *monads*, rather than about phenomena; and although I cannot entirely agree with this, it is worthwhile to examine his assertion. To be more specific, if the word "state" here should be taken as a *state of a monad*, Leibniz must be talking about "a plurality of monads" and "their states." The significance of this interpretation is obvious. For, in the text of *Initia Rerum*, despite the appearance that Leibniz is talking about space and time of the phenomenal world, he also refers to "higher order of principles." Thus, although we can find no reference to monads in this text, it is obvious that Leibniz certainly needs higher order principles for determining the nature of space and time, and no such principles can be imagined except for those *governing* the activities of monads, and those *connecting* them to phenomena. This reading is supported also by Leibniz's assumption of homomorphism.

The problem in (1) is: what does "opposition" mean? Arthur, with no hesitation, interprets it as "incompatibility" of two states. It is true that Leibniz sometimes say that "time is the order of possible inconsistencies" (already quoted in Section16). Since any monad's state-transition must produce a *change*, a state and its successor must be *different* in their contents. But can this "difference between two consecutive states" be generalized to the "incompatibility of any two states" of a monad, or to

the “incompatibility of any two states of different monads”? This question will be taken up again, when we introduce the notion of “world-state” (Section 20).

We will come back to this problem shortly, but Leibniz’s example mentioned here comes from *phenomena*, i.e., “we deny what occurred last year and this year are simultaneous,” because these two sets of events involve “incompatible states of the same thing.” This is not specific enough (and that’s the problem), but we can easily fill in details. For example, I visited France and only France last year, but I visited only England this year, and these two are incompatible *if they occur in the same year*. This suggests that the “opposition” Leibniz refers may well be *conditional opposition*, as it were, something like “two states involves opposition if they were brought to the same circumstance.” In passing, it should be noted that these examples from *phenomena*, by themselves, *do not* indicate any inconsistency of our interpretation, because *no one* can tell what those states of a monad are like! We have to conjecture by way of examples of *phenomena*. Moreover, we should refrain from saying that the word “simultaneous” (*simul*, in Latin) *must* imply a *temporal* concept; because Leibniz (especially in his later years) is firmly committed to the *non-existence of time* in the monads. Leibniz may well be talking about *both* temporal concepts *and* their metaphysical basis. Arthur may take this interpretation, which may be named “Double Interpretation,” although he does not distinguish time and its metaphysical basis. However, it is understandable that many interpreters have been puzzled by this passage, because Leibniz says nothing, in this text, how we should construct space and time from the activities of monads in the realm *without* them. I am going to propose, later in this paper, a way to deal with this challenging question.

(2) Si eorum quae non sunt simul unum rationem alterius involvat, illud **prius**, hoc **posterius** habentur. (Gerhardt M, *ibid.*) If one of two states which are not simultaneous involves a reason for the other, the former is held to be *prior*, the latter *posterior*. (Loemker, *ibid.*)

A most natural reading of this statement (in terms of *metaphysics*) is: take two states $[x]$ and $[y]$ of a *single* monad, and the former comes before the latter in the *order* of this monad’s sequence of states (determined according to its transition function). Since any later state is determined by its immediate predecessor and the transition function, the predecessor is “a reason for the successor,” and this relation of “giving a reason” looks *irreflexive* ($[x]$ is not a reason of itself), *asymmetric* (if $[x]$ is a reason for $[y]$ then $[y]$ cannot be a reason for $[x]$), and *transitive* (any previous reason is also a reason for any later states). Notice that all these observations nicely hold for my informational interpretation, in terms of the transition function of a monad.

However, in (1) Leibniz was talking about states of *different monads* also. Then how should we relate (2) with (1)? In view of this question, Leibniz's continuation of explanation is very interesting.

(3) Status meus prior, ob omnium rerum connexionem, etiam statum aliarum rerum priorem involvat, hinc status meus prior etiam rationed involvit status posterioris aliarum rerum alique adeo et aliarum rerum state est prior. (Gerhardt M, *ibid.*) *My earlier state involves a reason for the existence of my later state. And since my prior state, by reason of the connection between all things, involves the prior state of other things as well, it also involves a reason for the later state of these other things and is thus prior to them.* (Loemker, *ibid.*)

Now we have to be *very careful*. Each monad "represents" the whole world, all right. But so far, we have (in this paper) understood that, because all monads, together with their *whole sequence of states* (changes), are given at once, God arranged that each monad has its own sequence *as if* it represented (or reflected) the whole world, although, in reality, there are *no communications* among them; and this is the Pre-established Harmony. Thus, (3) must be interpreted with this "*as if*" clause in our mind.

But what Leibniz is trying to establish is clear enough, whether or not his reasoning behind it is valid.

(4) Et ideo quicquid existit alteri existenti aut simul est at prius aut posterius. (Gerhardt M, *ibid.*) *Therefore whatever exists is either simultaneous with other existences or prior or posterior.* (Loemker, *ibid.*)

This is indeed a striking "conclusion"! And Arthur's (and later, J. A. Cover's) job is to reconstruct this whole reasoning into a valid reasoning, based on the essential features of Leibniz's metaphysics. It should be clear by now, the main problem is: how to connect the order of state-transition of a single monad with the order of state-transitions of other monads (and possibly, of all monads). The most important clue Leibniz has given is the "connection between all things."

So, let us review how Arthur tries to reconstruct. The crucial part is as follows, although I have changed the wording and notations (my own notation for expressing a state of a monad was introduced in Part 1, Section 13): Arthur points out that the transitivity of ground (reason) holds (his Axiom 1, Arthur 1985, 301).

(A1) For any states $[a]$, $[b]$, $[c]$ in the state-transition of monad m , if $[a]$ is a reason for $[b]$ and $[b]$ is a reason for $[c]$, then $[a]$ is a reason for $[c]$.

Also, because of the nature of ground or reason (on my interpretation, state-transition), if a state is a reason for another, this relation is asymmetric (his Axiom 2, *ibid.*).

(A2) For any $[a]$, $[b]$ of the states of monad m , if $[a]$ is a reason for $[b]$ then $[b]$ is not a reason for $[a]$.

I cannot accept this *as an axiom*. Because, although I am sure Leibniz would accept this, logically the possibility of a “loop of reason” is left open. Namely, it is logically possible that $[a]$ is a reason for $[b]$ and $[b]$ is a reason for $[a]$. This complaint may look trivial, but it turns out later (Section 21) that this point is relevant to assessing the scope of the Leibnizian scheme of the theory of time. And I may add that these two axioms are perfectly satisfied by any transition function of a monad, *except for* this possible loop. (A1) and (A2) mostly hold, because of the *order* of states and the nature of transition function; but transition functions can contain a loop, repeating the same cycle. Further, the following (his Axiom 3, *ibid.*) is more problematic.

(A3) For any $[a]$, $[b]$ of the states of monad m , $[a]$ is a reason for $[b]$ or $[b]$ is a reason for $[a]$, if and only if $[a]$ and $[b]$ are incompatible.

Where does this axiom come from? Arthur is obviously appealing to (1) (Arthur 1985, 269), because he explicitly says “*one state is simultaneous with another if and only if it is not incompatible with it.*” Thus, if $[a]$ and $[b]$ are incompatible, either $[a]$ precedes $[b]$ or in reverse order, and the contrary also follows. But there is something strange in (A3). All the states of a single monad are *uniquely ordered* (Leibniz says “series”) by its transition function, and moreover, the *whole sequence* is given *at once*, when God created the monads. This means that the set of all such sequences (transition functions) *must* be compatible (compossible); and further, *given this context*, any two states must be compatible, since the whole world is already consistent (maximally consistent). Thus (A3) seems to be *invalid*. It is misleading, in the first place, to formulate it this way, since a monad’s states are not a mere set but a *sequence of ordered states*. Hence, it is *pointless* to say if any two states in this sequence (their positions in it are *necessarily* different) are compatible.

This observation shows that we have to interpret (1) very *carefully*. As I have already pointed out, all monads with their respective sequence of states exist without incompatibility. Therefore, they exist *simultaneously*, according to (1). In this statement, “simultaneity” does *not* have any temporal implication.

Having noticed this much, let us further follow Arthur’s argument. He proceeds to introduce a definition of simultaneity as follows.

(Def.) For any $[a]$, $[b]$ of the states of the monads of the world, $[a]$ and $[b]$ are *simultaneous* if and only if the two are compatible.

I have to repeat the previous remark again, this time emphatically. In Leibniz's metaphysics (*Monadology*), it does not make sense to talk about states of monads, taken out of their context. Arthur here is treating two states as a member of a *simple set* of states (without any structure). Moreover, as J. A. Cover (1997) aptly pointed out, the domain of quantification of (Def.) is quite different from the one for (A1)-(A3), the latter being *restricted* to the sequence of states of a *single* monad. However, Arthur tries to define the domain W for (Def.) in his Appendix (p. 304), but there again, he does not take the *order* of states into consideration. For, what he does for defining "*compossibility* of two monadic series (of states) , is to require that, for each state of one monad, there must be a *unique compatible* state in the other. Although this may achieve a 1-to-1 correspondence between the states in the two series, we have *no guarantee* for the correspondence of the *order* of states. We should *never* forget that each monad has a definite *order* in its state-transition, and the whole sequence is given at once.

Arthur is aware that we cannot generalize a result for a single monad, in order to define "*simultaneity* for different monads." The point is that we should obtain "*unique and well-defined classes of simultaneous states*" across the whole world of monads (Arthur 1985, 269). For this purpose, he tries to utilize Leibniz's insight of (3), the "*connection between all things*." I agree with this strategy, but I am afraid his use of the notion of *incompatibility* for this purpose, is not adequate at all. For, as I have already pointed out, *given the totality of the monads*, any two states, each from a different monad, are *all compatible*; then, applying (Def.), these two states must be *simultaneous*, and this result is *useless* for his purpose! Notice that the essential difference between Arthur's view and mine stems from our understanding of the relationship between the monads and *time*. He thinks time exists in the world of monads; I deny this, of course.

Now, turning to Arthur's formal derivation (Arthur 1985, 302), he claims that the following theorem follows from (A3) and (Def.):

(Theorem 4) For any states $[a]$, $[b]$ in the world, $[a]$ and $[b]$ are simultaneous if and only if *neither* " $[a]$ is a reason for $[b]$ " *nor* " $[b]$ is a reason for $[a]$ " (in other words, " $[a]$ and $[b]$ are compatible").

This claim is apparently without ground, since the domain for (A3) and that for (Def.) are different, but Arthur tried to fill in the gap, as I have already pointed out. But despite this, (Theorem 4) is a trivial consequence from the fact that "any two

states, each from a different monad, are compatible,” as was pointed out in the preceding paragraph. Thus, it is clear that Arthur has completely failed to capture Leibniz’s insight of (3), and his definition (Def.) is useless.

The reason why the “derivation” of (Theorem 4) is funny can be shown another way. Suppose $[a]$ is a state of one monad and $[b]$ is a state of another monad. Then, since there is no communication between the two monads, neither “[a] is a reason for [b]”, nor “[b] is a reason for [a]”. But since these two states come from a different monad, (A3) cannot be applied even if we admit it. And the fatal defect of (Def.) is that it disregarded the *order* of states, emphasizing only *compatibility*.

You may recall that in Part 1, I explicated Leibniz’s distinction between active and passive in terms of the hierarchical structure of a program (Sections 9-13). There, we have relied on Leibniz’s saying that “a monad provides an *a priori* reason for what happens in another.” The reader may cite this and argue that “a monad can provide a reason for some of another monad’s states.” But notice that my explication *presupposed* the context of an *organization* of monads and the programs in that organized machine (cellular automaton). Thus, my reconstruction in that context retained all of the structures (some are no doubt *ideal*, but “divine machines” are organized by God, I presume) monads can supply. Thus, my strategy is completely different from Arthur’s I have criticized; my criticisms all depend on the fact that Arthur neglected *transition functions* and *orders of states* generated by them.

20. J. A. Cover's Improvement?

J. A. Cover (1997) tried to improve Arthur's attempt. Setting aside all of his discussions of "reductive strategies," the novelty he added to Arthur's attempt is a new rendering of Leibniz's insight in (3) in the preceding section. Let us briefly review.

Since Arthur has failed to secure an adequate connection between the states of different monads, Cover tries to define "a world-state as maximal state of affairs" (Cover 1997, 312. I am here concentrating on his Second Version). He says "we shall be thinking of times as we think of possible worlds, in delineating them along logical grounds: times, like worlds, are maximal, consistent, and closed." Notice the word "logical grounds." What does this mean? He is suggesting the following:

Take the set of all states of the monads of a given world (here, the structure of a monad's states according to their order is neglected); and form all possible (consistent) sets of states from the original set of states; then we should have all maximal consistent sets of states, and these sets are guaranteed to differ from each other. (My paraphrasing, from Cover 1997, 312)

Although I myself cannot agree with this strategy, because it disregards the most essential feature of the world of monads (each transition function generates a *unique order* of the states of a monad), we have to see what Cover is trying to get at. Obviously, he is assuming that each of such maximal sets provides a *world-state*, which is meant to correspond to an "instantaneous state of the whole world." But notice that the *order* of states of a monad is disregarded when we assumed the "set of all states," so that we have *no guarantee* that the information of *order* is contained in any such maximal sets. The same is true of a "world-state" thus obtained; so don't be misled by its name, and whether Cover's "world-state" is *worthy* of that name is an open question!

Then, Cover goes on to introduce another trick. A state of a monad is said to contain a world-state only if it expresses or represents the world state. Here, it is clear that Cover tries to capture Leibniz's (3) in this form. Namely, any state of a monad represents the whole world, its "instantaneous state" so to speak, in its own way.

Finally, Cover defines simultaneity as follows:

(Cover's Simultaneity) Two states $[a]$ and $[b]$ (from the whole world) are simultaneous if and only if the world-state contained by the one is identical with that contained by the other. (Cover 1997, 312)

This idea is ingenious. But it is also clear that the whole project depends on the notion of "world-state." Does it make sense to put all states of individual monads into a single *set*? As I have repeatedly said against Arthur's attempt, any state of a monad does not make sense *if separated from* the original sequence of states of *that* monad, because the individuality (identity) of that monads entirely depends on that *sequence* itself. This maneuver is *against* one of Leibniz's essential assertions, i.e., precisely the assertion that there must be an essential connection between all things (by the pre-established harmony). Thus I don't think it is admissible to separate a state of a monad from its original *order*, and I don't think it is possible to construct a "maximal set of states" out of these separated states. Even if that were possible, any world-state thus constructed would have *lost* the information of "order" of individual states. Since the *order* of each state in the sequence of states of a monad is determined by its *internal principle* (transition function, in my word), it is one of the *essential features of reality*. Thus, Cover's attempt leaves one *essential* problem unsolved: How can we assure that the *original order* of states of each monad is recovered by his definition of simultaneity? I agree that the idea of world-state is excellent, but I consider the idea of constructing it from a *maximal set* is wrongheaded.

I can understand the reason why Arthur and Cover had to stick to this sort of maneuver, because they wished to define simultaneity in terms of *logical relations* (giving a reason, and incompatibility) *alone*. This is, in some sense, a *brave* attempt. But having seen their failure, we have to begin anew; we have to find another way for reconstructing Leibniz's view expressed in (1)-(4) of the preceding section. I will try to distinguish a "state" of a monad (which means that "state" has an implicit reference to that monad and the order in its sequence of states), and its "representative content" (to spell out this, we have to refer to the whole world and its states).

21. A Finite Model of Monads

In order to illustrate the main features of my proposal, let me first present a simple model of the world of monads. This is a “toy-model” with 4 monads, each having only 3 states. The reason I have chosen the number 4 is that a 3-dimensional space becomes possible if there are 4 or more objects in the phenomenal world (thus, there must be at least 4 monads as the basis of 4 objects); but right now, this is not important. In terms of this toy-model the reader may be better equipped with several notions necessary for understanding Leibniz’s metaphysics, and his theory of time. But, since this model *already* incorporates *my interpretation*, I warn the reader in advance, to be careful. My argument for defending this interpretation will begin in a moment, after the model is presented; so until then, it may seem a dogmatic presentation. But I prefer this way, since the reader can clearly see (I hope) what I am trying to establish.

Further, in order to help the reader, I will disclose my strategy at the outset. The first toy-model is easy to understand, and useful for showing several important features of *Monadology*, but it has a grave defect: it cannot provide a basis for *continuous* time. Thus we have to extend our model to the infinite case, (1) countable case which is a rather straightforward extension of our toy-model, and (2) continuous case, where the state-transition of a monad is continuous (Section 22). It will turn out that only (2) can be suitable for Leibniz’s theory of time, but (1) is useful for proving some important features of his theory. And after summarizing Leibniz’s metaphysical basis of time, we will proceed to outline how he can construct time in our phenomenal world on this basis.

Let us begin. Monad 1 has 3 states, and its sequence of states is (arrow indicates order): $[a] \rightarrow [b] \rightarrow [c]$. Likewise, Monad 2: $[d] \rightarrow [e] \rightarrow [f]$, Monad 3: $[g] \rightarrow [h] \rightarrow [i]$, Monad 4: $[j] \rightarrow [k] \rightarrow [l]$. These 4 monads constitute the whole world. And recall that, according to Leibniz, each monad represents (by its state or perception) the same world, so that by introducing the symbol R for representation (which needs *coding*, you may recall), the state $[a]$, for example, can be expressed (tentatively, because it may be safer to say “[a] contains $R([a][d][g][j])$ ”) as follows:

$[a] = R([a][d][g][j])$, or rather $[a] = R_1([a][d][g][j])$, since this is representation by Monad 1.

Here, I am assuming that the *order of states* is essential for describing the world, so that an “instantaneous” state of the world is determined by the states with *the same order* (I will argue for this point in the following Section). Thus, the conjunction “[a][d][g][j]” may be regarded as a “world-state,” as J. A. Cover termed (but, obviously,

I have *reversed* the order of his strategy). Any state may well produce *something else*, since I have insisted on the need for *coding for phenomena*, how the world looks to each monad. If we wish to express this aspect, we need another symbol for coding of phenomenon, Ph , and $R([a][d][g][j])$ and $Ph([a][d][g][j])$ must be distinguished. Now, although any representation of the world may have distinct parts and confused parts, this all depends on which monad, or which group of monads we are talking about (in this toy-model, we completely disregard cellular automata composed of monads). The same can be said about phenomena, Ph . And this aspect can be handled by adding a *subscript* (which indicates the monad that has this representation) to R and Ph . But for simplicity, we will often neglect this (my symbolism here is tentative, anyway), when talking about *general* features. More important is that Ph can contain R within its content (you may notice *recursion*, again, here), like

$$Ph([a]) = Ph(R([a][d][g][j])).$$

And in order to avoid misunderstanding, I have to add that phenomena *neither add anything to, nor subtract anything from*, the state (i.e., perception or representation) of a monad. Otherwise, both world-states and representations would be disturbed, and this is disastrous. Ph is *solely dependent* on R (and God's coding), and it may be likened to something like "self-monitoring" of a monad, but we can of course maintain Leibniz's distinction between "well-founded phenomena" and other phenomena. We have to discuss this problem later, but in the present model, it is not relevant.

Now, in order to make use of our model, let us ask several questions which are relevant to our interpretation of Leibniz's statements (1)-(4). By way of answering these questions, I will also state my reasons for defending my interpretation.

First, are $[a]$ and $[b]$ compatible? My answer is (i) "yes, of course," in one sense, and (ii) "no, of course not," in another sense. For, on the one hand, (i) *if we know* these two states belong to the same Monad (its sequence), obviously compatible, since the whole sequence must be consistent, in the consistent world. On the other hand, (ii) *if we know* these two are two consecutive states (there must be *change*) of the same Monad, the *contents* of the two must be *different*, and so incompatible *in the sense*: "they cannot be placed in the same order." Notice that any state represents a "world-state" so that *difference implies incompatibility*. Now, what makes this difference of my two answers? Obviously, whether or not to *count* the *order* of each! In (i), the order is already taken into consideration, and in (ii), only contents are considered and moreover put into the same order (thereby *disregarding* the original

order). Thus, as I have already suggested in the previous Section, the “opposition” Leibniz mentioned can be understood as “conditional opposition.” This must be particularly emphasized, because the totality of all *different sequences* of states exist in the *timeless* realm of the monads. Moreover, this conditional opposition applies *both* to reality (monads without space and time) and to phenomena (in space and time). This clearly shows that our Double Interpretation (Sect. 19) of Leibniz’s four statements can be maintained together with a *homomorphism*.

Then, are $[a]$ and $[d]$ compatible? The answer is “yes,” but this time, their subjects are different and *the order is the same*. However, if you ask “Are they compatible, if they occur in the same Monad 1 and in the same order?,” then the answer is “nonsense,” rather than “no.” Such a condition destroys the *identity* of Monad 1 altogether! We are asking a meaningless question for Leibniz, because the identity of any Monad is *solely* based on its perceptions (states). From this consideration alone, we may become suspicious of such projects as Arthur’s or Cover’s. Thus, we should be very careful, not to attribute too quickly such a strategy to Leibniz himself. This means that we have to add a lot more words for interpreting Leibniz’s brief statement (1). He must have been looking for an *interesting and useful correspondence* (simultaneity) among the states of monads. This is my main motive for presenting my toy-model.

Thirdly, we may ask “Is it possible that state $[a]$ occurs twice in a Monad?” (Here, “state” means “representative content,” since we are envisaging the possibility of assigning two different orders.) Obviously, the following repetition is precluded, because there must be a *change* in any state-transition:

Monad 1’: $[a] \rightarrow [a] \rightarrow [c]$

But what about this?

Monad 1’’: $[a] \rightarrow [b] \rightarrow [a]$

Offhand, it seems we cannot preclude this possibility, since a finite automaton with this transition is perfectly possible. For Leibniz, all possible worlds are, each, a maximal consistent world, but this means (i) a “maximal consistent set” of possible transition functions (sequences of states). Does he require, in addition, (ii) “*each world-state is maximal*”? (ii) is much stronger than (i), but (ii) is what Cover assumed. If this were the case, then any recurrence of the same state in a monad would be precluded. Here, Leibniz’s requirement that “each monad represents the same world” is relevant. If Monad 1’’ were possible (*ceteris paribus*), we would have the following two representations of Monad 1’’:

First $[a]$ contains $R([a][d][g][j])$ and second $[a]$ contains $R([a][f][i][l])$

And this seems impossible, for how can we make the two representations the same? Now, I am confident that Leibniz would say, for any monad and its representation, the following holds:

(5) For two world-states $W_i \neq W_j$, $R(W_i) \neq R(W_j)$.

If this is added, we can definitely say that the preceding two representations of Monad 1" are different and hence incompatible. This example is very instructive. For, if we can construct world-states from the sequences of states of the monads given in the world, based on the *order* of states, then, *with some additional assumption* (such as (5)), we can *prove* that (i) any two world-states are different and hence incompatible (in the same order), and that (ii) any two states (their representative contents) of a *single* monad are incompatible. Thus, we can reproduce whatever results Arthur or Cover can *correctly* derive from their attempts. I will show my proofs in the Appendix of this Section. But, since my proof needs an *additional assumption*, this shows that Leibniz's theory of time is *more flexible* than Arthur or Cover has imagined; for with a different assumption (suppose the inequality of the first half of (5) does to hold!), the order in the monadic world can be even *cyclic!* For, the same world-state is followed by a unique state, which must be exactly the same as the previous successor; thus the same cycle begins anew! Although you may object that the principle of identity of indiscernible prohibits this, it is easy to understand that the "second" occurrence is *identical* with the "first" (the order has a *loop*) so that this does *not* violate the principle. And exactly this can happen to the *initial* state, such as $[a]$! It does not have any predecessor (in our model), but if any "later" state were to jump to it (thus making a loop, and we can imagine such a transition function), the state-transition can continue forever.

The preceding consideration shows that Cover's assumption of *maximality* of a world-state is just *one* of such assumptions (from my point of view), and it tends to conceal other possibilities contained in the Leibnizian scheme of the theory of time. Although our model is a toy-model, it can suggest such other possibilities, and its essential features can be easily extended to any model with denumerably infinite monads.

Thus, although we have to take Leibniz's preceding requirement (of connection) into consideration, I think we can still explore the *flexibility* of the Leibnizian scheme for the theory of time. We can see a beautiful lesson of his requirement "everything is connected," and it can certainly strengthen the requirement of consistency. However, even at this stage, we can see that there is a room for other

assumptions, and depending on such assumptions, the whole sequence of world-states may change, and the resulting order may or may not allow *recurrence* of the same state. If it were to recur, the world would become a *cyclic* world, the same cycle repeating infinitely, which is unacceptable to Leibniz (but this possibility may be interesting to some of the modern cosmologists!).

Let us turn to another important question, which is relevant to (3), “connection between all things.” Let’s take *[b]* of Monad 1. What does it mean to say “its prior state (i.e., *[a]*) involves the prior state of other things as well”? My answer is something like this: The prior state *[a]* contains a representation $R_1([a][d][g][j])$, and the prior state of Monad 2, 3, and 4 are represented in it. Leibniz’s original phrase (within the quotation) seems to presuppose a 1-to-1 correspondence (I prefer this neutral word to “simultaneity”) between these prior states. That is to say, within the context of discussing “simultaneous, prior, and posterior,” he mentions “the connection between all things” and relate it with “a reason for the later state” (this reason determines the next state). Unless *the prior states are all aligned* (1-to-1 correspondence), how can they determine the later states of the same things? For the reader who wants to ascertain this, I will repeat the quotation (3) in the following:

(3) My earlier state involves a reason for the existence of my later state. And since my prior state, by reason of the connection between all things, involves the prior state of other things as well, it also involves a reason for the later state of these other things and is thus prior to them. (Loemker 1969, 666)

I know Arthur and Cover will object that “Leibniz first gave his definition of simultaneity, and then introduced ‘prior/posterior’ distinction, so that alignments are already given.” I don’t agree, since Leibniz’s definition, *as it stands* (but he may well have a *reason* for this definition), cannot give any desired alignments of states, since it does not refer to the *order* of states. As I have already pointed out (in Section 19), even the *whole sequences of states* of all monads can be “simultaneous” according to his definition. That’s the reason for my adopting the 1-to-1 correspondence among the states, *according to their order*, which naturally leads to World-States, as defined in the following Figure 10 and summary of our model. This is the *only one*, among many possible 1-to-1 correspondences, which can *preserve the order for every monad*.

Monad	State of order 1	State of order 2	State of order 3
1	[a] (R ₁ (W ₁))	[b] (R ₁ (W ₂))	[c] (R ₁ (W ₃))
2	[d] (R ₂ (W ₁))	[e] (R ₂ (W ₂))	[f] (R ₂ (W ₃))
3	[g] (R ₃ (W ₁))	[h] (R ₃ (W ₂))	[i] (R ₃ (W ₃))
4	[j] (R ₄ (W ₁))	[k] (R ₄ (W ₂))	[l] (R ₄ (W ₃))
World-State	W ₁ = [a][d][g][j]	W ₂ = [b][e][h][k]	W ₃ = [c][f][i][l]

Figure 10: A Finite Model with 4 Monads

From this Figure, the reader may be able to understand that the world-states must be already (logically) prepared in order to talk about each monad's representation of it. And this point is crucially relevant to my objection against Cover. Each monad's sequence of states must be already (logically) given, in order to construct a world-state. And if this is to be successful, there must be all unique one-to-one correspondences of states *throughout* the whole world of monads; otherwise Cover's "world-states" may be *merely ideal* (to borrow Leibniz's word) without corresponding counterparts in reality. My proposal utilizes a natural correspondence of order based on the *given timeless* world, whereas Cover assumes maximal consistent sets of states (separated from their order). If he can *prove* that his world-states are all identical with mine, then I will praise his ingenuity, but our results are happily identical. But if not, then certainly he is wrong and I am right, since mine does *not* change anything in the order of the all sequences of states in the world of monads.

In sum, then, our world of monads (the toy-model) can be described as follows:

Monad 1: [a]→[b]→[c]; Monad 2: [d]→[e]→[f]; Monad 3: [g]→[h]→[i]; Monad 4: [j]→[k]→[l].

World-States: W₁ = [a][d][g][j], W₂ = [b][e][h][k], W₃ = [c][f][i][l], and W₁ → W₂ → W₃

Each state of each monad represents the corresponding world-state, so that $[a]$, e.g., must contain at least the following part: $R_1(W_1)$. Likewise for other states, and other monads, with respective subscripts for R .

The *order* of states of each monad (and the order of world-states, as well) is *not* temporal, since the whole sequences exist in the world *without* time. But this order does provide the *basis* of time in the phenomena, and this phenomenal time should be *continuous, quantitative* (continuity and metric of time are added by the *coding* for Ph), and reproduce the *same order* in it, generating a *temporal order*. Quantitative time is necessary for all monads with finite capacity, in order to obtain knowledge of the world of monads *from phenomena*.

However, I have to point out here that our toy-model has a grave defect, because of its *finite* character. The continuous time must be *infinitely divisible*. Then, obviously, it is impossible that each divided parts of time corresponds to a different state or order. Let us recall what Leibniz said to Clarke (Sect. 18 above): “if the time is greater, there will be more successive and like states interposed.” In order to fulfill this requirement, given any two states of a monad, there must be *infinitely many other states in between*. This condition is exactly similar to the case of space and matter, which are also infinitely divisible. Thus any finite model cannot capture this aspect. But despite this grave defect, our toy-model can be instructive enough, for clarifying important features of Leibniz’s view on time.

In terms of this model, we may reconstruct Leibniz’s (1)-(4) as follows:

(1’) Since each Monad’s state (*together with its order* in the given sequence) is compatible with any other (since all sequences of states are compatible), they are said to exist simultaneously, but this is uninteresting. An interesting definition of simultaneity is obtained if these states are united by a unique 1-to-1 correspondence, and forming a unique World-State, *preserving the same order*. (The information of the world must be conserved!) Opposition (incompatibility) of two states can occur if and only if the order of each state is disregarded.

(2’) If one of two states which are not simultaneous involves a reason for the other, which means that their positions in the given sequence (according to the corresponding transition function) are different, the former is held to be *prior*, the latter *posterior*. This holds for each Monad, and for the whole world as well; but this merely repeats that the order of states is preserved, in the *timeless* world.

(3') Each Monad's earlier state involves a reason for the existence of its later state. And since its prior state, by reason of the connection between all Monads, the corresponding prior World-State involves a reason for the later World-State, and the order of prior-posterior is thus preserved.

(4') *Therefore whatever exists (any Monad, its state, and all sequences of states) is either simultaneous with other existences or prior or posterior.*

Although the reader may be puzzled by the list of entities in the parentheses of (4'), it is all right because "prior or posterior" applies *only* to states, the rest only simultaneous. This is the gist of my interpretation, in terms of my toy-model, as regards Leibniz's four statements. And what I am going to do in the next Section is to generalize this picture of the toy-model to Leibniz's world of monads. You may notice the essential difference of my interpretation from Arthur's or Cover's. I understand Leibniz's saying that "time is an order of succession" as an *elliptic* expression for "time is generated from the order of succession, together with God's coding for phenomena."

22. Extensions to the Infinite Case

Despite the defect of our toy-model, its extension to an infinite model (countably infinite model) is worthwhile, at least as a “first approximation” of a more satisfactory reconstruction of Leibniz’s theory of time. And with this extended model, I will show the following two, as was promised in Section 21. A further extension to the *continuum* of order will be presented in the latter half of this section.

- (i) Any two world-states are different and hence incompatible (in the same order).
- (ii) Any two states (their representative contents) of a single monad are incompatible.

For the following proof, the reader may mostly rely on the previous finite model, because the following extension is straightforward. Further, the proof can be extended to the case where monadic states are continuous and dense.

Now, since we disregard here the idea of organized groups of monads (a sort of “monadic” cellular automata), we may arrange all monads on an imaginary 2-dimensional table: The order of the states in any given monad is shown in the horizontal line (since it has a unique initial state $[x]$, this state is assigned *order-1*, and successors follow, and $[x^n]$ is assigned *order-(n+1)*), and all of the monads are aligned along the vertical line (see Figure 10 in Section 21). Any state of any monad can be identified by two numbers (n, m) , where n is the order of states, m the number of monad, and these numbers may be regarded as its “address.” See the following Figure 11.

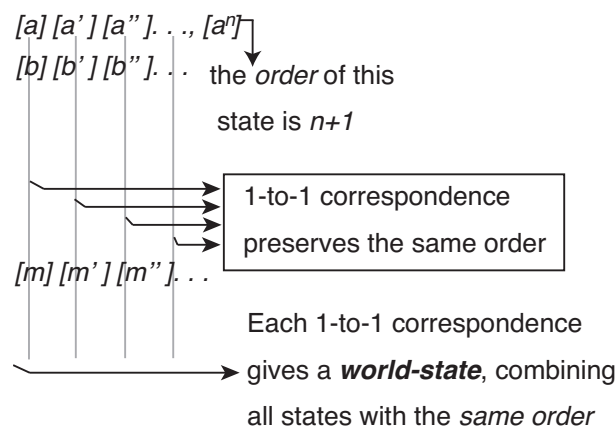

Figure 11: World-States by 1-to-1 Correspondence

Then, since it is quite straightforward to extend the one-to-one correspondence according to the order among the states, all of the world-states are obtained just as easily as in Figure 10 of Section 21. Each world-state thus obtained is maximal in the sense it contains all states of the same order and nothing else. Thus it gives the maximal information of the world in the corresponding order. Let us write the i -th world-state as W_i .

Now we have to introduce one assumption which is acceptable to Leibniz.

(NL, no loop) No loop exists in the sequence of the world-states.

Clearly, (NL), together with other conditions of Leibniz, implies that the world-states are all *different*, and that they change forever (if there is a loop, there can be only a finite number of different states). This further implies that any two such states (i.e., their representative contents) are incompatible (in the same order), since if they were assigned the *same order*, for some monad they would have to attribute two *different* states, which is impossible.

(INC) For any W_i and W_j ($i \neq j$), the two are incompatible.

This is nothing but (i) above, so it has been proved from the assumption (NL).

In order to prove (ii), we utilize the condition that a state represents the corresponding world-state. Let $[x^n]$ be a state of the monad with address $(n+1, m)$. Then,

$[x^n]$ contains $R_m(W_{n+1})$,

by the requirement of the "connection of all things." So take any *other* state of the same monad, say $[x^k]$. Then, $k \neq n$ and

$[x^k]$ contains $R_m(W_{k+1})$,

and since $W_{n+1} \neq W_{k+1}$,

$R_m(W_{n+1}) \neq R_m(W_{k+1})$, hence $[x^n] \neq [x^k]$,

which means that any two distinct states of this monad are different, and hence incompatible. Thus (ii) has been also proved.

Now, since (i) and (ii) are proved with the assumption of (NL), each world-state is maximal not only in the sense that it contains all compatible states of the same order, but also in the sense that “if you add any state not contained in it, then it becomes inconsistent,” thus Cover’s assumption of maximality is indeed satisfied. However, I have shown that this conclusion depends on (NL), and if (NL) is not satisfied (that’s certainly possible, if we do not stick to Leibniz), Arthur’s or Cover’s intended conclusion may not hold. Moreover, I don’t see how they can prove, *starting from* (i) and (ii) (note that the direction of proof is reversed), that the order generated (by Cover’s method) is the same as the *original order* as I have assumed; for when they formed the set of all states of individual monads, the information of the original order is lost.

Leibniz, in his letter to de Volder (20 June 1703) said, “I had said that extension is the order of possible coexistence and that time is the order of possible inconsistencies” (Loemker 1969, 531). The last part of this statement, then, does indeed hold both in the form of (i) and (ii), and this statement may be cited as one of the evidences that Leibniz already had a similar view as that expressed in his “Metaphysical Foundations of Mathematics” (1715). However, it seems that Leibniz assumed that, for each monad, the order of states is *already* given.

The preceding extension is still short of Leibniz’s view on time, since he is clearly committed to the dense ordering, which amounts to assuming a *continuum* of states (and hence order of states) of any monad. That is,

(Cont.) Given two different moments a and b of time, there must be always another moment c such that it enters in between a and b .

In order to satisfy this requirement for the phenomenal time, what is needed in the state-transition of a monad, and how should we modify the basis of time in reality? Obviously, our countably infinite sequences of states cannot satisfy (Cont.).

However, the problem may not be as hard as one may imagine. For the possibility for mapping one continuum onto another (or more carefully put, mapping a ordered set with the same density as a continuum onto another set or continuum) is quite flexible. Leibniz’s *Monadology* assumes the initial state of a monad, which corresponds to the beginning of the phenomenal time. Thus, the continuous time should form a continuum such that the beginning is closed but the end is open (forever). And we know that such a continuum can be mapped onto the interval $[0, 1)$. And our problem boils down to this: How can we introduce alignments of the states of all monads, supporting the concept of simultaneity? We can find an

answer to this question, very easily! As long as we keep *the order of states intact*, any alignment or mapping is all right! See the following Figure.

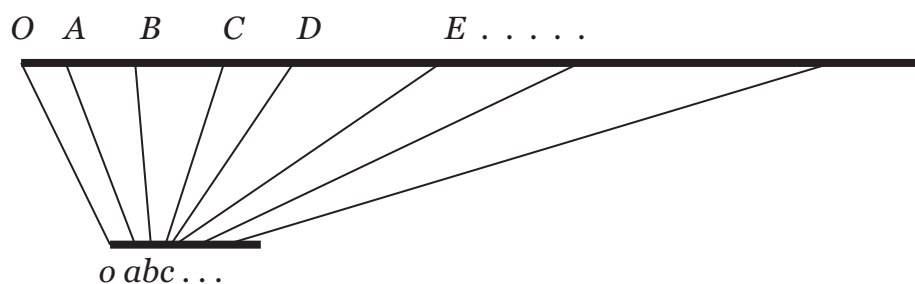

Figure 12. Alignment of States between two Continua

The upper line and the lower line are two continua, where only the left ends are closed, at O and o respectively. Then, as long as the lines of alignment or mapping do not cross, any alignment will be a respectable candidate for one-to-one correspondence. And between any two points, say A and B , there are infinitely many points interposed, and each can have its counterpart, likewise, in the lower continuum. Thus, alignment of states is as easy as the case of our previous countable case.

Moreover, since these two continua (of monadic states) do not imply any *quantity*, God has a total freedom to choose His coding for time! In other words, any such alignment can be the basis of time in the phenomena, and God will certainly choose the *best alignment* in view of his his *best plan*! Therefore, we do not have to give up any important conclusions obtained from our countable model. In conclusion, even if the states of a monad are ordered continuously (according to Leibniz's principle of continuity), there is no difficulty for alignment of states of different monads, and there is definitely a solid basis in reality for *simultaneity*, *priority*, and *posteriority*.

23. Summary of my Interpretation of Leibniz's Basis of Time

I have already said enough about my own interpretation of Leibniz's theory of time, and about the reasons for it, by way of a toy-model in Section 20 and the two infinite extensions in Section 22. Therefore, in this section, I will reproduce the four quotations from Leibniz, and summarize my own reading of these texts, as far as it is possible, in conformity with the essential tenets of Leibniz's metaphysics.

- (1) *If a plurality of states of things is assumed to exist which involve no opposition to each other, they are said to exist simultaneously.* (Loemker 1969, 666)
- (2) *If one of two states which are not simultaneous involves a reason for the other, the former is held to be prior, the latter posterior.* (*ibid.*)
- (3) *My earlier state involves a reason for the existence of my later state. And since my prior state, by reason of the connection between all things, involves the prior state of other things as well, it also involves a reason for the later state of these other things and is thus prior to them.* (*ibid.*)
- (4) *Therefore whatever exists is either simultaneous with other existences or prior or posterior.* (*ibid.*)

As regards (1), I have already pointed out that all monads (together with their transitions functions) exist simultaneously, but *without any temporal implication*. Therefore, if Leibniz means "simultaneity of *states* of monads," simultaneity can only mean the *identity* of order, which means a unique 1-to-1 correspondence among the states of different monads. Since I have said enough in (1') of Section 21, I will not repeat anymore.

(2) is unproblematic, if it is concerned with the transition of states within a single monad; here again, "prior" and "posterior" can be understood without any temporal implication, because they are concerned with the *order* of states in a given sequence (remember that the *whole sequence* is given at once). Or, if Leibniz means a continuum of states, as in Appendix (B), "continuum of states" may be better.

The problem is with (3). But recall that, according to Leibniz, any monad can represent the whole world, and this means "the whole *sequence* of each monad in the world." Recall also that this was the reason why Leibniz could talk about his Demon, who can possibly know the *whole history of the world* from a piece of matter. Now, in view of all this, together with (1)-(3), my reading strongly suggests that Leibniz is implicitly assuming there is a *one-to-one correspondence* among the

individual states of all monads, even though we have to say that this correspondence may be an *ideal* relation (because there is no communication among monads, in reality). For each monad, Leibniz admits that it can represent the whole world in its states (actually, the sequence or continuum of states); in addition, he seems to assume that any *single* state (perception) can represent the *relevant portion* (states) of the whole world. Otherwise, it becomes quite hard to make sense of (3).

The suggested one-to-one correspondence can be as easily obtained as in our toy-model, because whether or not the states are discrete or continuous, they are given at once when God created the world. And each state can represent within itself, all states aligned with itself (a world-state, in short). However, by God's coding for representation R , this representation or perception is different in each monad, and moreover, mostly confused. But the important point is that this alignment (one-to-one correspondence) does not disturb the order of states in any monads. And at the same time, this alignment can reproduce what Cover termed "world-state." The circumstance is exactly similar with the toy-model case in the Section 21. All monads are "synchronized," so to speak, by their orders of states; but again, we are not yet committed to any temporal concept, since we are merely talking about the *order* in the realm of monads *without time*. Nevertheless, this *order* can be regarded as a *real* (not *ideal*) feature of all monads, as long as the internal principle of change (transition function) of each monad is its *essential* feature. And most importantly, Leibniz's conclusion (4) can be derived, again without any temporal implication, within the realm of the monads. Furthermore, this "order of succession" (which is *not yet time*) can provide the *basis of time* in the phenomenal world.

Thus, my proposal mainly focuses on the *order* of states, rather than on compatibility or incompatibility of states, since the latter can be derived from the former (together with an additional assumption). And the reason I am against any strategy to *begin* with the notion of incompatibility is, "incompatibility of states" depends on conditions (i.e., conditional). And as I have shown in Section 22, whatever Arthur and Cover can say *correctly* can be reproduced in my interpretation. Thus I have to conclude that my reconstruction of Leibniz's reasoning behind his statements (1)-(4) is much better than those which starts from the notion of incompatibility of states.

Now, having finished my reconstruction of (1)-(4), it remains to add Leibniz's final conclusion from all this, as the following (5):

(5) *Time is the order of existence of those things which are not simultaneous.* Thus time is the universal order of changes when we do not take into

consideration the particular kinds of change. (*Initia Rerum*, Loemker 1969, 666)

The word “simultaneous” has been understood, so far, as the unique “one-to-one correspondence” among the states of the monads. But since we have now finished our discussion of the basis of time, we can begin to move on to the *time in the phenomena*. Our “Double Interpretation” is grounded on Leibniz’s assumption of *homomorphisms* between the monadic realm and certain features of phenomena, and the *qualitative* similarity of *order* and *metric time* can be easily exploited. So that, Leibniz can, from now on, be understood as talking also about time in our phenomenal world.

In (5), we have to notice the word “the universal order.” I understand this means that “the order as the basis of phenomenal time is universal in that the states of each monad, as well as the world-states, are arranged according to the *same order*.” This feature is perfectly realized in my interpretation and reconstruction. And further, I may add that the order of the phenomenal events, “mental” as well as “physical,” expresses the *same order* (although it is expressed *confusedly*, in terms of *quantitative* time which contains additional features).

Before proceeding to my treatment of time in the phenomenal world, it should be appropriate to add my remark here on the following question, which may be lingering in the reader’s mind: If the world of the monads is *timeless*, it should be *static*; then how can the *activities* of the monads take place in it? This question seems to be in Richard Arthur’s mind, when he attempted a “reconstruction of Leibniz’s time in the monadic world” (see, e.g., Arthur 1985, 276-7, where he regards “appetition” as a principle of “temporal change” and “becoming”).

I have to point out, first, that “timeless” does not imply “static.” The latter word may imply there are *no activities*, *no changes*. But Leibniz is clearly committed to the existence of “activities” and “changes of states” of each monad. And I have repeatedly pointed out there are *changes of states* in a monad, according to its transition function (internal principle given by God). These changes do *not* take place *in time*, of course, but *throughout* the sequence of states, *according to the transition function* of each monad, and thereby determines the *order* of the states. This is what Leibniz means by the “activities of a monad.” This may look strange to most people who cannot think of a world without time. But the whole sequence of natural numbers is given in the same way. There are two manners of speaking. On the one hand, we may say “all of the sequence of states of a monad is created at once,” and on the other hand, we may express the same thing by saying “the order

of states in this sequence is *generated* by its transition function." "Generation" in the latter does *not* presuppose time.

Now, in order to *explain* time, philosophically or metaphysically, one cannot assume time (at least, Leibniz must have thought so). Therefore Leibniz chose the way from the timeless world to the phenomenal world. If you say "timeless" implies "no activities" and "no forces," then even God would be "without activities and forces." Thus, as long as we stick to the way Leibniz chose, we have to understand that "timeless" implies neither "no activities," nor "no forces," nor "no changes." Leibniz's use of such words as "active" or "force" (as well as "perception") must be understood in a *technical sense*, which is meant to provide the *basis* of the same words in the phenomenal world. That's the reason why he introduced the distinction between the "primitive" and the "derivative."

24. Metric Time in Phenomena

How can we give a metric to time? Here, we have to remember that *motion* is inseparable from *time*. In *Initia Rerum* Leibniz gave many important hints as regards the connections among geometry (hence, space), time, and motion.

Immediately after the conclusion (5) of the preceding Section, Leibniz begins to talk about *magnitude* of time *and* space.

(6) *Duration is magnitude of time.* If the magnitude of time is diminished uniformly and continuously, time disappears into a *moment*, whose magnitude is zero. (*Initia Rerum*, Loemker 1969, 666)

The second sentence says that time is *homogonous*, and this is a sort of extension of the principle of continuity. Although I have disregarded this notion of *homogony* when I mentioned De Risi's work on *Analysis Situs*, the reason for this omission is that I wished to discuss it *here* in relation to *both* space and time. Recall De Risi's clear reconstruction (Section 17) of Leibniz's view on space: space is the locus of all loci, or of all points, but "points" are a bearer of relations. These points are unextended, but extension and space can *disappear into a point by a process of continuous change*; this is something like a definition of *homogony*. Whereas *homogeneity* is defined in terms of equality and similarity (e.g., two congruent triangles, or two similar triangles are homogeneous). Thus *homogony* is different from *homogeneity*, but the latter is continuously connected with the former. Further, Leibniz says:

Although they are not homogeneous, time and a moment, space and a point, boundary and bounded, are nevertheless *homogonous*, because one can disappear into the other by a process of continuous change. (Loemker 1969, 668)

Moreover, the analogy between space and time is further extended:

Time can be continued to infinity. For since a whole of time is similar to a part, it will be related to another whole of time as its part is to it. Thus it must always be understood as capable of being continued into another greater time. Similarly, *solid space or amplitude can also be continued to infinity*, since any of its parts can also be taken as similar to the whole. (*Initia Rerum*, Loemker 1969, 669)

Thus, it is clear that Leibniz is thinking space and time quite analogously. The relation between space and a point, and the relation between time and a moment (point of time, so to speak) exactly correspond to each other. And let me remind you again of De Risi's summary: space is *constituted by*, not composed of, places (loci as points), as Leibniz sometimes say (De Risi 2007, 173-4).

Then, why not repeat an *exactly analogous* argument for the possibility of the *metric* of time, step by step? Metric of space was introduced by the notion of *congruence*; then why not introduce *congruence for time* (duration) too? De Risi refused this step, because he stuck to the notion of *situation*, which is concerned only with spatial relations. But if situation (which reflects relations among monads, connected by simultaneity, or the one-to-one correspondence I mentioned) gives rise to *spatial* relations, then it is easy to imagine that a *similar* thing can give rise to *temporal* relations. Situation is of course related with the order of coexistence among monads, so that the "analogous thing" must be the *order of succession*; namely, quantitative and continuous time (in the phenomena) can be obtained on the basis of the order of succession, the "universal order of changes" in (5) in the preceding Section. Thus the problem boils down to the notion of *congruence for time*, for duration. And if we look for something helpful for this purpose, an obvious candidate is *inertial motion*. Since any inertial motion is *rectilinear* and *uniform*, if we can measure the *length of its finite portion of path*, from any point to any other point in the same *path*, this can be made the criterion of *temporal congruence* in the phenomenal world. In short, the temporal congruence may be reduced to the congruence of length.

Although this scenario may come to our mind, we have to be careful. For it is not clear whether the notion of inertial motion can be defined *without* appealing to any temporal concepts. Newton, for example, clearly *presupposed* both space and time for constructing his system of mechanics, the notorious absolute space and absolute time. Leibniz is obviously against such a project. His relational theory of space and time *must* avoid any such projects; otherwise he will lose most of the attractive features of his dynamics and metaphysics as well. On the other hand, it must be remembered that spatial continuity and spatial metric are achieved by introducing congruence, *congruence of length*, in particular, by *Analysis Situs*. Spatial metric is obtained not from nothing but from repetition of unit length, so to speak, on the basis of *Analysis Situs* which is meant to capture some *qualitative* features of the realm of monads.

With these preliminary considerations in mind, we will examine Leibniz's paper. After a brief remark on homogeneity, Leibniz begins to discuss *motion*, *path*, and *trace*. Motion is of course change of situs. Then, comes the following three statements:

The mobile is homogenous to the extended, for even a point is thought of as movable.

A *path* [*via*] is the continuous and successive locus of a movable thing.

A *trace* [*vestigium*] is the locus of a movable thing, which it occupies at some moment. (*Initia Rerum*, Loemker 1969, 668)

Thus it seems Leibniz is suggesting *time* (moment) can be related to *space* (extension) by means of *motion*. Time and space cannot be homogeneous, but the two can be connected by homogeneity, because a *movable* point (which is homogeneously related with space) occupies a *locus* at each *moment* (that is *trace*), and the collection of all such loci is *path*, a *spatial* entity. In other words, if a path (or its finite portion) of a mobile can be perceived (by our consciousness), the corresponding motion can be *represented* in it (as a special entity for which simultaneity is satisfied). And it seems Leibniz is indeed trying to adopt this line. In order to see whether this is true, let us follow the relevant part of his paper for a while.

After discussing quantity and relations according to quantity, Leibniz touches on the law (principle) of continuity. Then, abruptly (so it seems) he turns to *situs* again.

Situs is a certain relationship of coexistence between a plurality of entities; it is known by going back to other coexisting things which serve as intermediaries, that is, which have a simpler relation of coexistence to the original entities.

But we know as coexisting, not merely those things which we perceive together, but also those which we *perceive successively* [Coexistere autem cognoscimus non ea tantum quae simul percipiuntur, sed etiam quae successive percipimus], provided only that, during the transition from the perception of one to that of the other, the former is not destroyed and the latter generated. From the latter requirement it follows that both coexist now, at the present moment in which we attain the latter perception; from the former it follows that both existed when we experienced the former thing. (*Initia Rerum*, Loemker 1969, 671, my italics, and an original Latin sentence inserted.)

The second sentence, I claim, provides the *missing link* between time and situation. The italicized words “perceive successively” is crucial, although it is accompanied by two important conditions that (i) one object is perceived at an earlier moment and *persists until* another object is perceived at a later moment, and that (ii) the latter object can be regarded as *coexisted* at the earlier moment. However, I don’t see why (ii) holds, by those provisos Leibniz stated. I suspect he might have meant to repeat, the other way round, another successive perception from the latter to the former. But anyway, it is reasonable to assume these conditions hold for geometrical objects such as two separated points or figures; for, in order to perceive a *long* line, it takes some time to see one terminal point and then another point far away; and although we thus successively perceive this line, the two points no doubt coexists and have been coexisted. Now, if Leibniz were talking about geometrical objects in *timeless* realm, he would not have had any need for bringing in “successive perceptions.” Thus I take it that he is thinking of the relation of geometry with *dynamics*; because, motion is nothing but a change of situation so that dynamics, in treating motion, presupposes geometry, and, further, geometry and time *must* be combined.

Notice that there is a *basis in reality*, for this “successive perception” in the phenomenal world, because of *simultaneous situation* and *successive order*. Corporeal bodies are situated and hence their relations are subject of *Analysis Situs*, and *change* of situation takes place according to a certain *order*, which is grounded on the *order of state-transition* in monads. The order of state-transition is timeless, but our perception of phenomenal change takes time, which somehow reflects that timeless *order*. The relations of “simultaneous, prior, and posterior” are qualitative, and if these *qualitative* relations are transformed (via coding) into *quantitative* relations, time appears (to us, humans, e.g.). Moreover, although Leibniz said that *motion* does not exist, the *path* of a motion can exist, because the successive states of monads together with their order exist in the timeless realm, and hence the *path* is nothing but their *representation*. Since the path is a *spatial representation*, it can exist in the phenomenal world.

Leibniz continues, and surprisingly (so it may seem to some readers, but naturally to me) comes back to the notion of *path* (which was already introduced in relation to a motion) again, as follows:

There is, moreover, a definite order in the transition of our perceptions when we pass from one to the other through intervening one. This order, too, we can call a *path*. (*ibid.*)

What is he going to discuss? If we consider two different objects or points (in space), there can be *infinitely* many different paths between the two. If the matter is left at this stage, everything is a mess, a chaos. He then says, there must be a path “that is most simple, in which the order of proceeding through determinate intermediate states follows from the nature of the thing itself, that is, the intermediate stages are related in the simplest way to both extremes.” In short, he defines distance. “It is this minimal path from one thing to another whose magnitude is called *distance*” (*ibid.*). This suggests *optimality* (or *teleological law*) which he is very fond of.

But the reader may wonder: “Why does he take such a roundabout way to define distance?” I cannot but say “he must have had, in his mind, a close relationship between motion and geometry”; recall that inertial motion is *rectilinear, uniform*, and based on the *nature of body*. And, of course, at the root is the essential difference of time from space in their origins, space (situation) from the order of coexistence, time from the order of succession. Despite this difference, distance must be connected with motion and time, as well as with space. But remember that “minimal” and “straight” are different, except for Euclidean geometry!

In sum then, I understand that one of the main purposes (among others) of Leibniz’s exposition in his paper is this: Leibniz aimed at founding the congruence of time on the congruence of distance (length), by means of the path of a motion. Inertial motions, in particular, can be a good candidate for supplying a unit of time, since it is *uniform* and *rectilinear* (its path is a straight line). In passing, however, we have to mention De Risi’s observation that Leibniz’s definitions of “straight line” are not exempt from some flaw (De Risi 2007, 226-247); this may well be relevant to the characterization of inertial motion too. Anyway, Leibniz tried to prove his “absolute space” (see Section 17) is Euclidean (De Risi, 247).

For a while, we neglect the problem of the foundation of the law of inertia (this problem was discussed in the 19th century by such people as Mach). But Leibniz certainly regarded the law of inertia, as one of the indispensable elements of his dynamics, and moreover, also as founded on the nature of body (without considering its problem within his *relational theory* of space and time). And, although the concept of the “inertial system” is an invention of the 19th century, Leibniz’s dynamics as well as Newton’s mechanics can be regarded as holding in any inertial system. On this reasonable assumption, it seems any inertial motion is ideally suited for providing a unit time (in terms of the distance it passes). However, since Leibniz cannot assume any absolute frame of reference, the problem of *relativity of motion* may well be an obstacle for this purpose. Thus, we

have to look for an adequate and *specific* way to define temporal congruence in terms of distance. Leibniz does not seem to have provided any, although it is quite clear that his dynamics essentially depends on it.

25. How to introduce Temporal Congruence?

As regards collisions, Leibniz referred to the relativity of motion, and asserted that only the *relative velocity* of two colliding bodies is relevant. Can the same strategy work for utilizing an inertial motion for determining the criterion of temporal congruence? It seems it can. Recall the two examples of collision in Part 1, Sections 6 (Figures 3 and 4). Before and after the collision, the motion of the two bodies is an *inertial motion* relative to each other. However, these examples treated collisions on a straight line, and not ideal for measuring a distance. So let us choose an example of two bodies A and B (large enough for carrying an observer on it) in parallel motion, like Einstein's examples of two inertial systems. Einstein assumed identical clocks and measuring rods are used in each system. But, we assume only identical (i.e. congruent) rods can be used for measuring length on each body. Because of the relativity of motion, each observer on A and B may think "I am at rest and you are moving." And if the other moves one unit length (the length of the rod), each can judge one *unit time* has passed.

This point can be illustrated by Figure 13. The observer on A marks when the left end of his rod coincides the left end of B's rod. And he marks again when the right end of his rod coincides the left end of B's. Thus the *path* of the left end of B's rod can be represented by the straight line between the two marks; and its length (distance) can express *one unit of time*, of this relative motion.

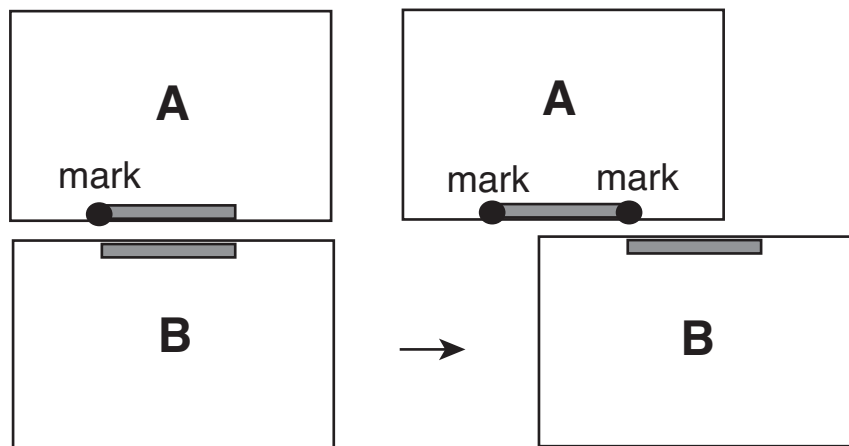

The two marks determine a path,
and the distance between the two marks
represents one unit of time.

Figure 13: Inertial Motion and Unit Time

This method works because inertial motion is *uniform* and its path is a *straight line*. We utilized Leibniz's definitions in his *Initia Rerum*. If the observer on A makes similar measurements with respect to another system C, as in Figure 14, the *proportion* of the speeds of two inertial motions can be obtained. If the relative motion of B is taken as the standard, C's speed is one half. Since the rod is infinitely divisible, we can obtain any desired degree of speed, and hence of time. This process can determine a *metric* of time in the inertial system A.

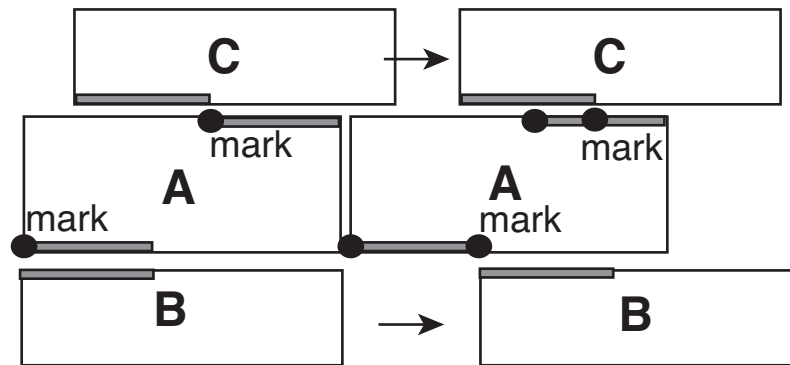

C needs 2 units of time to travel the same distance.

Figure 14: Proportion of two Speeds

Thus in order to introduce unit time (via length, distance), we need no clock; parallel inertial motions and book-keeping of their paths (by means of marking) are all we need. And exactly the same holds for B and C too. And once A's unit of time is obtained, congruence of this unit can be repeated any number of times we wish. And if this fact (still confined within a single body or system) is ascertained, on the basis of this fact we can introduce *other means* for measuring time; e. g., any periodic phenomena which are judged to be *uniform* by the preceding "inertial clock." Thus Leibniz can use a pendulum clock improved by Huygens for time-keeping.

Then, an "inertial clock" or any other clocks based on it can be applied to non-inertial motions too. Suppose B's motion relative to A is not inertial but uniformly accelerated like a free fall. Then A's book-keeping, this time with an appropriate clock, will produce, as each unit time passes, a sequence of marks, such as: 1 unit distance from the 1st to 2nd, 3 units from 2nd to 3rd, 5 units from 3rd to 4th, etc., just as Galileo observed in his experiment of a ball rolling down a sloping plane. Thus the *speed* of this motion and the acceleration (rate of increment of velocity) can be measured; and by adding information of the (relative) *direction* of a motion, the metric can be extended to *velocity*.

However, here, we have to cite very illuminating remarks by Julian Barbour, commenting on Galileo's experiment of projectile, using a water-clock.

First, it is water, not time, that flows. Speed is not distance divided by time but distance divided by some real change elsewhere in the world. What we call time will never be understood unless this fact is grasped. Second, we must ask what change is allowed as a measure of time. Where does this come from? It looks as if we can get into an unending search all too easily. No sooner do we present some measure that is supposed to be uniform then we are challenged to prove that it is uniform. (Barbour 2000, 96)

At the heart of the problem of defining time (or congruence of time), there are these two points. In Leibniz's case, (i) uniform inertial motion can be used for measuring time and relative speed, but (ii) *uniformity* of inertial motion is presupposed. The latter is nothing but the problem of the foundation of the law of inertia (the last paragraph of Section 23). We will leave (ii) for a while and concentrate on (i). The problem of simultaneity (in the phenomenal world) is lurking, if we wish to integrate two *different sets* of measurements (distance and time) from two bodies or systems in *relative motion* with each other. In each system, geometry of space and measurement of time can be all right, but how can this information be shared with other system? Remember we are now talking about two systems A, B in the *phenomenal* world. In addition, "how A's measurements *appear* to B" may well be a part of the phenomena B observes. Leibniz may have been unaware of this problem, but we, after Einstein, can certainly raise this question.

The reader may protest against this: "You are being anachronistic, and raising a question Leibniz has never dreamt of!" Well, I am *not* sure whether this objection does *justice* to Leibniz. I am going to argue that Leibniz's dynamics and his relational theory of space and time have enough *potentiality* for handling such questions.

26. Relativity of Motion and Simultaneity

The problem of “simultaneity” has already appeared in Sections 19-22. But I have adopted the interpretation that those passages from *Initia Rerum* are primarily concerned with the *basis* of time, not with the simultaneity in the phenomenal world. That’s the reason I have substituted “1-to-1 correspondence” instead of “simultaneity” there. Thus if Leibniz discusses congruence of time and genesis of time in the phenomenal world (and this is my interpretation explained in the previous Section), it is precisely here that he should define *simultaneity which can be used in his dynamics*. On my interpretation, the essential problem is this: On the basis of the *unique order* of the states throughout the world of monads, how can we generate time in the phenomena? In order to answer this, simultaneity in the *phenomena* must be properly defined. I grant that I am depending on our hindsight after Einstein. But, at the same time, I have to point out that it is Leibniz, not Newton, who emphasized the notion of simultaneity; Newton concealed this problem under the guise of “absolute time.”

The speed of light was not known exactly in Leibniz’s days, but after the Danish astronomer Ole Rømer announced (1676) that the speed is finite, some scientists including Huygens and Newton supported this view. Then we may safely infer that Leibniz also knew this fact, because Huygens even tried a rough calculation. But the theory of electro-magnetism appeared only in the latter half of the 19th century, hence any such ideas were not accessible to Leibniz. Thus it is only *after* Einstein’s monumental paper of 1905, that the speed of light gained the pivotal role in physics. I have no intention to deny this. However, it is also undeniable that the relativity of motion plays an essential role in Leibniz’s dynamics, and this alone may vindicate my attempt to investigate the hidden *potentiality* of Leibniz’s dynamics. For, Leibniz’s relativity obviously suggests that the laws of dynamics must be the same for all observers, irrespective on which system an observer is located, irrespective their state of motion, and how far away one observer is separated from another. But in order to keep our problems within a manageable size, let us confine ourselves only to inertial systems. Even with this restriction, then, by adding the possibility that the flow of information to a far-away location may take some time, the notion of simultaneity may suffer an influence from the relativity of motion.

We can find many textual evidences (I will refrain from enumerating, since it is boring) for asserting that Leibniz was well aware that a flow of information in the phenomenal world takes time. For, the phenomena are governed by the laws of motion, and this means any flow of information depends on such motions, and like

any change of motion by collision, information flows through the boundaries of two or more bodies. But we have to distinguish the flow of information *within* a “divine machine” (cellular automaton) and the flow *between* two or more of such machines (Part 1, Section 12). This distinction was crucial for my informational interpretation elaborated to some extent in Part 1. In raising the question of relevance of relativity to simultaneity, I am exclusively concerned with the flow of information between two *separated* bodies (cellular automata) *in relative motion*. Then, according to Leibniz’s view, any perception of one body by the observer on the other body must be mediated by innumerable bodies in between the two; hence it seems the flow of information inevitably takes some time, not immediate. This supposition is all we need.

Then, what is going to happen when two bodies are in relative motion (for the sake of simplicity, we may assume it is a parallel motion). Even when the two are closely located, as in our Figures 13 and 14, there is a problem. How does the measuring rod in one body *appear* to the observer in the other body? You may recall Einstein’s argument in his famous paper (1905) on relativity. Einstein of course added, in addition to (1) the principle of relativity, (2) the principle of invariance of the speed of light. We are right now assuming Leibniz can agree on (1), but he does not know (2).

These assumptions *may* seem to prevent us from proceeding any further, as regards Leibniz’s possible solutions of simultaneity in the phenomenal time. But we can try two candidates as “adventures of ideas.” Whether or not they be successful, we can obtain some important lessons from such adventures.

- (i) One obvious and straightforward hypothesis is this. Despite the relativity of motion, we may stick to the classical way. We have found the basis of simultaneity in the realm of monads, in Section 23, i.e., there is a unique 1-to-1 correspondence among the state-transitions of all monads and the world-states, which preserves the same order. And a most straightforward way to generate time in the phenomena is to extend the *same order* throughout the phenomenal world, by adding a uniform and quantitative metric to this structure (this may be the possibility entertained by Arthur and Cover). The ground for uniformity is in inertial motion which is regarded by Leibniz as based on the “nature of body” (see Section 2). Then simultaneity is automatically determined for any events founded on the same world-state. Thus, this time is exactly similar to Newton’s absolute time, but founded on the monads and God’s coding (for generating quantitative time in phenomena, from an atemporal order).

(ii) But there can be another way, compatible with the basis of time in the monads. We have emphasized the need for coding, when we consider phenomena, because a state $R(W)$ (representing a world-state W) of a monad cannot be identified with a phenomenon $Ph(R(W))$ generated by the state. Thus we distinguished coding Ph of phenomena from coding R of representation. And as I have already suggested, the rod and clock of one inertial system may *appear* differently to other inertial system, thus adding new *twists* to phenomena. This means, although the basis of space and time is the same for each body, phenomena (appearance) may well be different, including space (distance) and time (duration). The problem of metric has to be handled by taking this aspect into consideration.

Now, candidate (i) is certainly possible. Although it may be even reasonable if we confine ourselves to classical physics, it may not deserve the name of “adventure.” I am far more interested in (ii), since if it turns out possible, it can certainly show a far greater scope of Leibniz’s theories of dynamics, space and time. We will examine these two in turn, in the following two Sections.

27. Classical Time in Leibniz's Dynamics

Leibniz's reconstruction of time in the phenomenal world has at least one great philosophical virtue, in comparison with Newton's theory of absolute time. That virtue is Leibniz's persistent emphasis on the importance of *simultaneity*. This point cannot be overemphasized, because Newton concealed, so to speak, the problem of simultaneity under the guise of absolute time. Moreover, Leibniz's time is truly relational, in that its basis is the order of succession, the order of state-transition of the monads. And we should not forget that the *basis* of temporal simultaneity is also given in the monads. In our present reconstruction (classical time), this order is directly transferred to the temporal order with no modifications except for *quantitative* transformation. Thus classical simultaneity emerges in the phenomena. Moreover, time is *irreversible*, because the original order is one-way, not reversible. Unlike Newton, Leibniz's classical time is not an "*a priori* assumption" but *derived* from his metaphysics, although as I have kept reminding the reader, God's coding must be assumed. And, finally, its derivation from *timeless* basis is really innovative and striking.

Now, since we have constructed metric time from inertial motion, and reduced temporal congruence to spatial congruence, we have related time and motion to space. Thus space, time, and motion are not independent but closely connected with each other. This is quite in accord with the ideal of the Leibnizian harmony. Further, in this context, because of the law of inertia, the space must be Euclidean. Isotropy holds, i.e., space is exactly alike in every direction. Likewise, inertial motion holds irrespective of direction. And since we derived temporal metric from inertial motions, temporal metric is also the same and uniform irrespective of direction. The magnitude of (relative) velocity is determined by reference to this uniform time (based on inertial motion). The only qualitative difference from Newtonian absolute time is that time may have a beginning, since Leibniz talks about the creation by God.

I do not know whether or not the following is a merit of this classical reconstruction of time, but it may be worth mentioning: This classical time does not preclude the possibility of Leibniz's Demon (Section 13). For, since at any moment there is a unique space (a surface of simultaneity, although it is 3-dimensional) containing all bodies in the phenomenal world and their information is all available to any observer at this moment. So, if there were an observer who could discern this information, together with the knowledge of the laws of nature, he or she can know not only what is happening right now, but also what has happened and what will happen. Unlike Laplace's Demon, Leibniz's Demon can obtain such information

(necessary data) from a piece of matter. This is because of the classical simultaneity which can go through all events, instantaneously, of the whole world. Since, according to Leibniz, a piece of matter can represent the whole world (through its basis, i.e., the monads constituting this piece), the Demon with its super-intelligence, can read off this information. Notice that if the speed of the flow of information (on the surface of simultaneity) has an upper limit, this is not assured despite its super-intelligence.

I think the only problem lurking in this reconstruction of classical time (for Leibniz) is the question of *consistency* with the relativity of motion. Leibniz seems to have thought Newton's argument for absolute space in terms of his "bucket experiment" (the surface of the water in the bucket becomes concave by the centrifugal force due to revolution) is not decisive (Clarke alluded to this in his 4th reply). But Newton's argument has an equal force in *inertial* systems, even if we discard absolute space and time. So unless Leibniz shows that he can explain the same phenomenon by his dynamics (with relational space and time) coupled with the relativity of motion, the question of consistency remains. As a matter of fact, although Mach suggested an informal idea in the 19th century, a solution was obtained only in general relativity, in 1985 (see Barbour and Pfister 1995, ch. 5).

For the convenience of our later comparison, a bit of symbolic representation is in order here. With an instantaneous world-state W , and its representation in each monad $R(W)$ (we need appropriate subscripts, but they are neglected for the sake of simplicity), an instantaneous phenomenon can be expressed by $Ph(R(W))$. Then, all of the preceding *metric* features of Leibniz's classical time stems from Ph , since this is the only place where the transformation from *qualitative* features to *quantitative* features occur. Although the reader may not have noticed this, this will become prominent in the following Section, where we will try a *relativistic* reconstruction, as an "adventure of idea."

28. Relativistic Metric in Leibniz

Now I am going to turn to candidate (ii) at the end of Section 26. At the beginning I have to warn the reader that this is an adventure in order to probe the *potentiality* of Leibniz's metaphysics and dynamics; I have no intention to allege Leibniz was entertaining this way of introducing time in phenomena. All I wish to show is that, despite the fact that Leibniz was unaware, an amazing potentiality was (logically) contained in his metaphysics and dynamics based on it.

It seems that Leibniz did not consider (well enough) the possibility that the flow of information may take time, and the speed of this flow cannot be infinite. Although he was aware that any causal process in the phenomenal world takes time, as was implicitly shown in his famous example of the "roar of the sea" (Section 12, and for Leibniz's original text, see Ariew and Garber 1989, 295-6, from the preface of *New Essays*), he does not seem to have considered its implications deeply. But suppose one day in the evening, around 1715 (his last full year), this possibility struck him, together with the idea that a kind of ether is the medium of this flow. Could he ever revise his theories of time and of dynamics, in order to adjust them to this possibility, *without changing anything in his metaphysics*? The last italicized condition is meant to preserve the basis of time in the monads in the *timeless* realm. To this question, I can definitely answer "Yes"!

There can be various hypotheses, but I can present the simplest immediately. Depending on our hindsight, we can extend the *invariance* of the law of nature not only to each inertial system but to the *speed of the flow (propagation) of information*, just as Einstein did. This is quite in accord with the relativity of motion Leibniz holds. For, although this speed becomes, in some sense, absolute, not depending on which inertial system we are talking about, Leibniz would not refuse this as long as this speed is one of the consequences from his dynamics and metaphysics. And since we are confining ourselves to considering only inertial systems, we also do not have to mind. "Relativity" and "relational" theories do *not* imply the absence of the absolute. Without something invariant, no intelligible theories may be possible, and this is one of what Leibniz has insisted on, throughout his middle and later periods.

Then all motions, *except for the flow of information*, are relative in the phenomena. We can even imagine the basis of this constancy of its speed: when God encoded timeless order of world-states in the phenomenal world, he has left one benchmark for all finite beings. That may well be a part of the pre-established harmony.

Then, since both the principle of relativity and the invariance of the speed of the flow of information are ready, Leibniz's version of "special relativity" is easily obtained. Or we may choose another formulation in terms of "Minkowski space," which utilizes a "space-time geometry"; although its metric is Euclidean for space, the overall metric is Lorentzian, as I have already explained in Section 16, Figure 9. God, instead of prescribing the two principles of dynamics for phenomena, may well have adopted the Lorentz metric which introduces a mutual dependence of space and time. And as I have already pointed out, this metric can be put into his coding for phenomena, $Ph(R(W))$. Notice that coding can be changed *without altering anything in reality and its essential features*. Thus, God can produce this relativistic metric *on the basis of* the order of succession of states in the world of monads. This means that the original order keeps its unique one-to-one correspondence, but in its *phenomenal expressions*, the *relativity of simultaneity* appears, and space and time, taken singly, are also relative. This is the reason why I have confidently asserted that the relativistic metric can be obtained by modifying *nothing* in the realm of monads. The trick is all contained in the coding part Ph .

Some reader may invoke Leibniz's Demon again, by saying "your relativistic metric will destroy the possibility of this Demon, because of the invariance of the speed of the flow of information." Yes, as it stands, this remark is right, as far as *our* world of phenomena is concerned. But there can be two ways to counter to this remark. One is to accept this and to regard "Leibniz's Demon" as an imaginative metaphor for illustrating a certain feature of *Monadology*. However, if we wish to extend our adventure, we can easily suggest a *relativization* of our relativistic metric. Since metric depends on Ph , not any other parts of $Ph(R(W))$, we can introduce *different metric systems* depending on the grades of monads. We humans have an *anima* with intelligence; but Leibniz entertained the possibilities of Angels and Archangels, and their *anima* should be far superior to ours. The phenomenal world may well look differently from ours; which means, even if they were governed by a relativistic metric, the speed of the flow of information may be *different* from ours, increasing as God may wish! In short, we can entertain the possibility of multi-metric systems of phenomena based on *exactly the same world of monads*. If we may depend on our up-to-date hindsight, theories of "Varying Speed of Light" (VSL) can suggest such possibilities, although the context and purpose are quite different (see Magueijo 2003 and Moffat 2008).

For the sake of brevity we will use "light" for "flow of information," thus meaning the "speed of the flow of information" by the "speed of light." Then the imagined Leibnizian double-metric system can be illustrated, in 2-dimensional Minkowski space, as in Figure 15. We assume the speed of light for Angels is quite close to

infinity, and the speed of light for humans is much smaller than this. In each case, time is expressed in length (ultimately based on a chosen “inertial clock”) and written usually as ct , where c is the speed of light (NB it takes 2 values, depending on the anima in question).

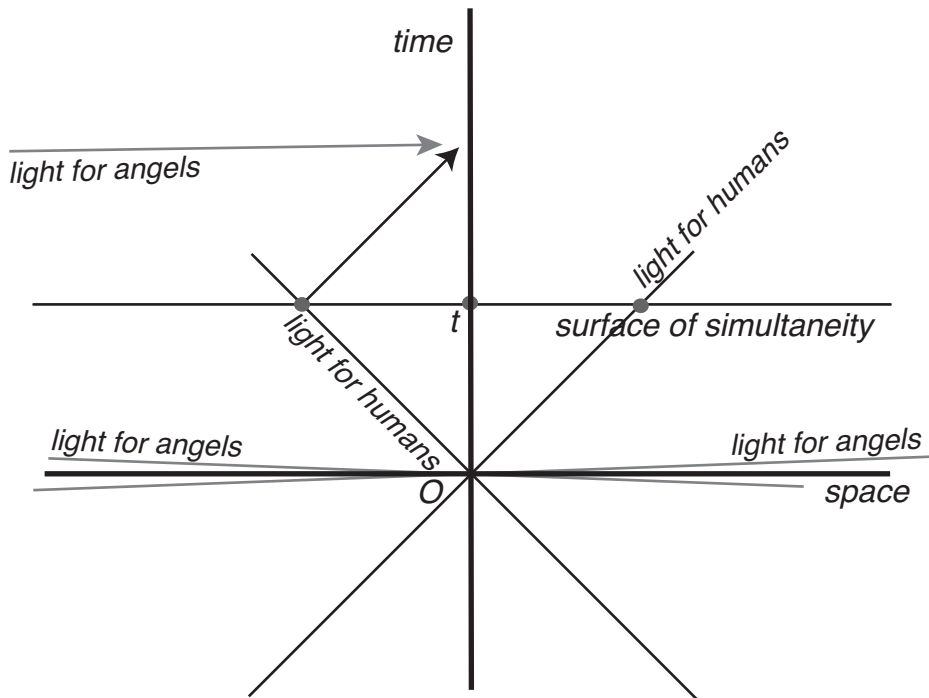

Figure 15: Bi-metric Relativity for Humans and Angels

The speed of light determines the upper limit of distance any piece of information can reach. Thus, for humans at time t , although the surface of simultaneity extends to infinity, information from a far-away location takes a lot of time for reaching them, and moreover, no one at O , e.g., cannot emit information to any location *outside* of the *future* cone-like sphere originating from that location. Likewise, no information from outside of the *past* cone-like sphere is available at O . Thus the limited sphere determined by the speed of light is usually called a “light cone,” in relativity theory. A light cone for angels (in grey lines) is far larger, which means they can collect far more information far more quickly.

Now one may ask: “Then how can an object at a location and moment *represent* the world-state, which covers at least an instantaneous whole of the phenomenal world?” Leibniz’s answer is: that object results from a group of monads, and its entelechy *represents* (that is, as a *state* of monad, $R(W)$) the corresponding world-state at that moment; but whether or not this entelechy can *have access to* or *know* that world-state, is another question, since the capacity of knowledge is always limited in a finite monad. Thus, I would claim my relativistic rendering of the

phenomenal world is perfectly consistent with what Leibniz says. Remember that a “world-state” is defined only in the realm of monads, not in the phenomenal world.

I do not know whether the speed of light for Angels can be infinite; but it *must* approach infinity, as long as Leibniz entertains the possibility of his Demon. If it is infinite, the relativistic metric coincides with the Euclidean, classical metric.

I will not continue my adventures any further, since I think I have already attained my initial purpose. Leibniz’s metaphysics, together with his dynamics and geometry, may be regarded as containing far richer and far broader potentialities than most scholars of Leibniz may have thought.

29. Mass and Energy

In view of the results obtained so far, we can come back to one pending problem as regards the relationship between *total living force* and *partial living force* (Part 1, Section 8). In terms of our modern notions, Leibniz's this distinction may well be related to *energy* and *inertial mass* in relativity. That's one of my reasons for pursuing a relativistic adventure in the last Section. If a relativistic metric is possible in Leibniz's dynamics, then this relation may not be a mere fancy, a mere faint analogy. It is certainly worth examining.

Let us recall his distinction. Living force is either *total* or *partial*. Partial force is either (a) "relative / proper" or (b) "directive / common": (a) belongs to the parts, and (b) is common to the whole. Relative or proper living force is simply the *force of interactions* between the parts (of a single body), and directive or common force is the force that which contributes to the determination of the *relative velocity* of the whole body (speed and direction) with respect to other bodies in consideration. And (a) plus (b) equals the *total living force* of a body.

Leibniz is clearly saying that aside from the kinetic energy of a moving body (in terms of the relative speed in a given context), we also have to consider its *internal energy*! Further, recall that, as long as we are entertaining the *relativistic metric* as regards Leibniz's dynamics, our considerations are confined to inertial systems. This is our context, and I have repeatedly cautioned that I am exploring the *potentiality* of Leibniz's dynamics. Another point of which I have to remind the reader is that the transition function (or program) of the dominant monad of an organism (Leibniz often calls it a "body") controls *both* of its activity and passivity (these two are inseparable, as I have argued in Part 1, Section 13). And I have argued for the relativity and contextual character of this distinction (*ibid.*)

Now we have seen in the previous Section, as a result of our adventure, that a relativistic metric for space and time can be easily obtained. Of course Leibniz did not, and could not, know this. But *we can* see this fact and combine it with the relativity of action and passion. Thus combined, the common living force (due to the relative speed v and the inertial mass m of the whole body, $mv^2/2$) and the inertial mass can be seen as closely related, the speed of light (i.e., the speed of the flow of information, in Leibniz) c mediating the two. Thus, Einstein's formula for rest energy

$$E = mc^2$$

can also be adapted for Leibniz's dynamics, and he might say that this rest energy corresponds to what he termed *proper living force*. Notice the corresponding formula holds (logically) in Leibniz's dynamics (as reconstructed in Section 27), as long as we adopt the relativistic metric in the last Section, whether or not Leibniz says anything suggesting it. In addition, Leibniz *indeed* made a remark in conformity with this formula. Thus my conjecture in Section 13 is confirmed.

Let me add the following remark. The classical mechanics are often called "Newtonian mechanics," despite the historical facts that many brilliant people such as Euler, Lagrange, Laplace, etc., have greatly contributed to its development. These people may be said to have explored the *potentiality* of Newton's original system. In view of this, I think it should be fair to try a similar, but belated, exploration of the potentiality of Leibniz's dynamics. At the same time, however, I also have to point out a serious difficulty at the root of Leibniz's project. So far, we have ignored the problem of the *foundation* of the law of inertia. We simply assumed Leibniz can use this law *in addition to* the relativity of motion; but this may not work. In the next section, we have to turn to this problem.

30. What is the Problem with Inertia and Relativity?

Leibniz does not seem to be aware of the problem of the law of inertia for his system of dynamics together with metaphysics. Among our contemporary physicists and philosophers of science, Julian Barbour is by far the most renowned for his consistent research on relational theories of dynamics. And he knows quite well the problem of inertia (the law and inertial mass as well). So let me begin with a quotation from his short paper:

Unlike his contemporaries Huygens and Leibniz, who both cheerfully used the law of inertia as the foundation of dynamics while stoutly maintaining the relativity of motion, Newton felt this problem so acutely that he could not conceive of any dynamics formulated without a rigid framework—absolute space. (Barbour 1995a, 7)

This remark has a sting for Huygens and Leibniz, as well as for Newton. It is true that the law of inertia, in one form or another, was already used before them by such people as Galileo or Descartes. Galileo was using his version as regards motions on the earth, so that his “inertial motion” is along a circumference of the earth (hence not straight), but *experimentally*, it worked well enough for Galileo’s purpose. For Huygens and Leibniz, an inertial motion must be uniform and on a straight line, whatever direction we may consider in the universe. But we may ask: what does *uniform* mean, and how can we know the path of that motion is *straight*? *If* we already have the criterion of uniformity, the uniformity of inertial motion makes sense, and *if* we may assume that our space is Euclidean then motion along a straight line is all right. But then, these two “*ifs*” must be shown to hold in the first place; just taking the law of inertia as “the foundation of dynamics” won’t do. To this question, add “the relativity of motion,” whether the motion is straight, circular, or curvilinear. Then *anything* may be taken as a frame of reference, and the law of inertia must be supposed to be holding in it. Can we say this law is the *same* as the “law of inertia” holding in another reference frame? Newton must have thought this is absurd.

Barbour’s diagnosis may be briefly summarized as follows. An “inertial motion” may be called a “cosmic drift,” but we do not know *whence* it comes and *what* determines its course (Barbour 2001, 477). It stands alone, as it were, disengaged from the contingent world (*ibid.*), including the earth, the sun, and the stars. This makes a sharp contrast against the relativity of motion, which makes everything relative to something else; collisions, in particular, are determined only by *relative* velocities. Yet, in order to explain projectiles, collisions, or centrifugal forces, inertial

motions must be presupposed. This contrast and the necessity of collaboration of the two, inertia and relativity, is the source of enigma.

Since the reader may be puzzled by any explanation only in terms of ordinary words, let me supply the following Figure, for illustrating the implication of the relativity of motion, a simple case of circular motion and a generalized case. You may reconsider the status of the law of inertia, in view of this illustration.

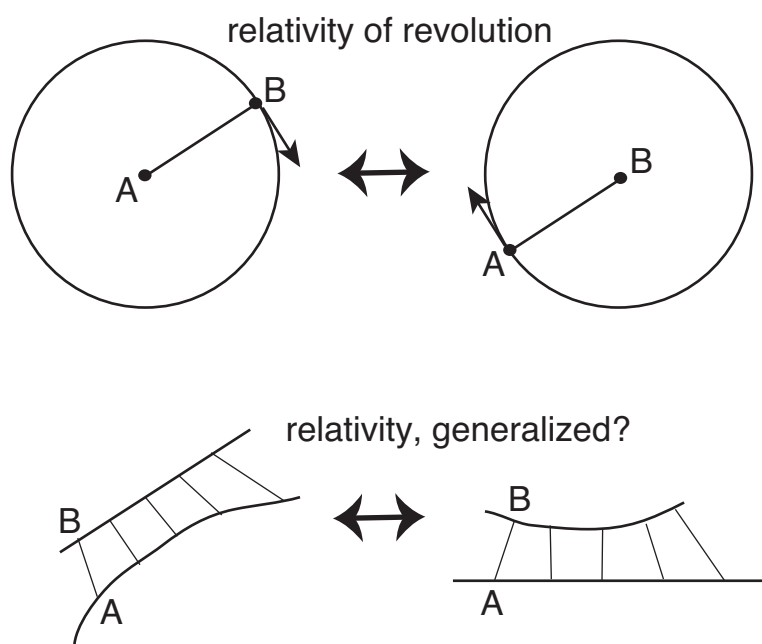

Figure 16: Can Relativity be Generalized?

With Figure 16, the reader may see the difficulty of harmonizing the law of inertia with relativity. See the upper figure of circular motions. Geometrically, it may be all right to say that the two ways of describing are equivalent, but it is not all right if we assume the *law of inertia*. If B is rotating around A in an *inertial system*, a *centrifugal force* arises for B, so that, *physically*, the two ways are *not* equivalent at all (this can be a version of Newton's argument). Thus we have to distinguish physical relativity from mathematical relativity. And you may also notice that the radius of the revolution *remains the same* in either way. In order to emphasize this, I inserted several lines of distance in the lower, generalized case too. Relativity does not mean "anything goes" but presupposes something *invariant*. Thus, in order to assert the relativity of motion, Leibniz should have put forward more careful arguments.

The conceptual apparatus necessary for a possible solution was not available to anyone, when Newton, Leibniz, and their contemporaries were writing. We need Gaussian coordinates and differential geometry, which Einstein utilized for

constructing his theory of gravity (it is usually called “general relativity,” but a caution is necessary for this word).

This enigma is a serious problem to be solved for Leibniz too. Was he ever aware of this problem? As far as I can see, within dynamics, he has not clarified the foundation of the law of inertia; he merely said inertia is given as part of *nature of body* (See Part 1, Section 3). However, unlike Huygens, Leibniz prepared his own metaphysics *Monadology*, in addition to *Analysis Situs*, as the foundation of his dynamics. Thus, if we wish to look for his argument for, or clarification of, the foundation of the law of inertia, we have to examine his metaphysics and *Initia Rerum* again.

31. How can Leibniz establish the Law of Inertia?

Let us recall our scenario (Sections 24, 25) for introducing the metric of time in the phenomenal world: Leibniz tried to derive the congruence of duration from the congruence of length, via inertial motion (this is my conjecture). The problem of this scenario is that the *uniformity* of inertial motion seems to be presupposed, and the uniformity of motion is nothing but another expression for saying that the path is *straight* and the *speed does not change*. Thus, the notion of “speed” is apparently presupposed for defining the congruence of duration. If this is the case, then our scenario is bound to fail, since a temporal concept (speed) is presupposed for temporal congruence. Is there any possibility for avoiding this vicious circle?

If we may bring in our hindsight, we can say that it is not advisable to concentrate on *the law of inertia alone*. We know, thanks to Julian Barbour’s research, that there have been several attempts to incorporate Mach’s ideas for reconstructing classical mechanics only in terms of relative quantities (see Barbour and Pfister 1995, 4). These were attempts solely in terms of dynamical concepts used in classical and relativistic theories, and often utilizing the full power of the modern analytical mechanics, in terms of the *phase space* in which we can express any trajectories of the *whole world* by a curve in that abstract space, and utilizing *optimization* (an older name is the “principle of least action,” which derives from one of Leibniz’s ideas) in one form or another. We should refrain from depending on this hindsight, because that will destroy Leibniz’s original ideas. Thus we have to stick to Leibniz’s own ideas, despite our (tentative) estimate that it may well be hard to obtain a satisfactory solution.

There may be some hope, however. In *Initia Rerum*, just after Leibniz has introduced “successive perception” for knowing coexistence, and extending the

notion of *path* to such successive perceptions, he introduced *distance*. Then by way of explaining it, he continues to discuss the *path of a point*. It must be a line. And if two points are given, the *simplest path* from one to the other is determined, which is nothing but a straight line. From this, he draws the following four consequences:

- (1) ... a straight line is the *shortest* distance between two points or ... its magnitude is the distance between the points.
- (2) ... the straight line is *uniform* between its extremities. For there is no determining factor given from which we can infer a reason for variation.
- (3) ... it follows from the definition that a straight line passes through those points which have a unique relation to the two given points, this relation being that of *maximal* determination.
- (4) it follows that a straight line is *uniform in all directions*; ... (Loemker 1969, 671-2; all italics and numbers in parentheses are mine.)

I believe these contain an important hint for a possible solution of our present problem. Leibniz seems to be talking about geometrical notions, but the whole context is still a sequel of *successive perception*. The word "path" is continually used from the previous paragraphs through these paragraphs. And the very phrase "path of a point" can be interpreted as suggesting "movable point." Since I have been arguing that Leibniz relates time to space (distance) via motion, a "straight path of a point" certainly has a close connection with inertial motion. This is my interpretation. Then, there can be a way to transfer the uniformity of straight line to the uniformity of inertial motion, without presupposing temporal uniformity; in short, the uniformity of inertial motion may be reduced to a geometrical uniformity, i.e., the uniformity of a straight line. And, the crucial link may be provided by *optimality*, as you can easily imagine from the words "shortest" and "maximal determination."

However, the uniformity of inertial motion has two aspects, a *straight line* and a *constant speed*. Even though the first aspect can be reduced to the uniformity of geometrical straight line, what can we do for the second aspect, the constant speed? To be more specific, motion is a change of situation, and an inertial motion can certainly be regarded as a motion with the *minimal path* between any two spacial locations. But this can explain only that inertial motion is along a straight line. Where does the *constancy of speed* come from? Here it seems we cannot expect any further assistance from *Analysis Situs*.

However, this tentative judgment may be a bit premature. For, we have not yet utilized many insights we have derived from Leibniz's metaphysics, *Monadology*. Any change of *situation* ultimately depends on the state-transitions of the monads, or on the change of *world-state*. Thus consideration of the *whole world* of monads may open a new perspective for our problem.

Since in Leibniz's metaphysics everything is connected with each other, the *whole world* can be regarded as *the* player. Here, Barbour's following remark is quite illuminating. Talking about his *Platonia* (relative configuration space, which reminds us of Leibniz's situations) as the arena for Machian dynamics, he says:

An arena is the totality of places where one can go in some game. But who is playing the game and where? In Newton's game, individual objects play in absolute space. In Mach's game, there is only one player — the universe. It does not move in absolute space, it moves from one configuration to another. (Barbour 2000, 69; see also the Appendix to this Section.)

This applies not only to Mach's game but also to Leibniz's game! Although he may deny that our *dynamics* can deal with the *totality* of the phenomenal world, his *metaphysics* is clearly concerned with the whole world of monads! Thus, it is at least meaningful to talk about the state-transition of the *whole world*, the unique series of world-states is the foundation of everything, including all changes in the phenomenal world. Although we do not know what this series is like, we can at least infer that this series underlies the *whole changes of situations* including inertial motions. Although we do not bring in analytical mechanics, we can extend Leibniz's notion of *path* to *changes of situation* resulting from the world-states. Recall a motion is a change of situation, and according to Leibniz, we should explain phenomena in terms of motions. Thus if we know a complete series of situations, we know the history of the phenomenal world. In other words, any *possible* path gives a possible history of the phenomenal world. Then, we can apply the consideration of *optimality* to such possible paths, and God should choose (as a consequence of his choice of the best world) the *best path* (history). In this choice, God must have given a unique metric for this path (otherwise phenomena are not possible for us, humans), which necessarily implies a unique metric for time, or a unique metric combining both space and time. Recall that this metric is contained in Ph of $Ph(R(W))$.

Of course there can be technical difficulties (for us, humans) even for deriving the law of inertia in a large *finite* world, as Barbour tells us (Barbour 2000, 115). Specifically, isotropy of inertia (inertia is the same, not depending on direction)

holds according to empirical evidence; but earlier attempts of a relational reconstruction of classical mechanics, this isotropy did not hold in galaxies (because of their distribution of matter, additional effects are produced). However, the preceding scenario has proved to work, as I have remarked at the outset of this Section.

Thus, although we cannot, from this general consideration alone, give any specific temporal metric to an inertial motion, taken by itself, our new perspective has given us a new scenario for determining the metric of the phenomenal world (space and time). By extending Leibniz's notion of path and applying optimality (but working out details may well need additional ingenuities), he could have given a metric to space and time, *without vicious circle*. Having ascertained this, then, the resulting metric may be either Classical (Section 26) or Relativistic (Section 27), or even more general. Even though the original scenario, as it stands, may have contained a vicious circle, we can always switch to this new scenario without any such vicious circle. And since inertial motion is certainly possible according to the new scenario (the Leibnizian space may or may not be Euclidean), we can use the results of the old scenario, at least as a tentative solution.

And in this context, it may be worth mentioning the following: Leibniz's insistence on the law of inertia and the straightness of inertial motion may be saved in a small scale, just as the Lorentz metric (of special relativity) is preserved in every *local Lorentzian frame*; and this plays an important role even in general relativity. Leibniz said *conatus* (effort) works in straight line, and that is the reason for his assertion that all curvilinear motions should be regarded as polygonal, having infinitely many *straight* sides. This assertion may look quite old-fashioned, but it is somehow reminiscent of a local Lorentzian frame. And as we will see in Part 3, Leibniz's speculation on gravity might be related with inertia, although this is a mere possibility at this stage.

Appendix to Section 31: Barbour's *Platonica* and *Shape Space*

Since Julian Barbour's work is quite useful for understanding what Leibniz is doing in his *Analysis Situs* and dynamics, let me insert a brief exposition of Barbour's *Platonica* and *Shape Space* derived from it. This material is adapted from my own book (2006) published in Japanese.

In order to develop his Machian dynamics (classical version), Barbour first introduces a *configuration space*. Following his own example, let us consider a toy-model, a world with only three mass points A, B, and C. These can form, generally, a triangle, and sometimes collapsing into a straight line on which these are aligned. A device for expressing all possible triangles in terms of the length of AB, BC, and CA is a 3-dimensional configuration space. Notice that such triangles (or lines) can express a *situation* in Leibniz's sense, i.e. an instantaneous situation of the *whole* phenomenal world.

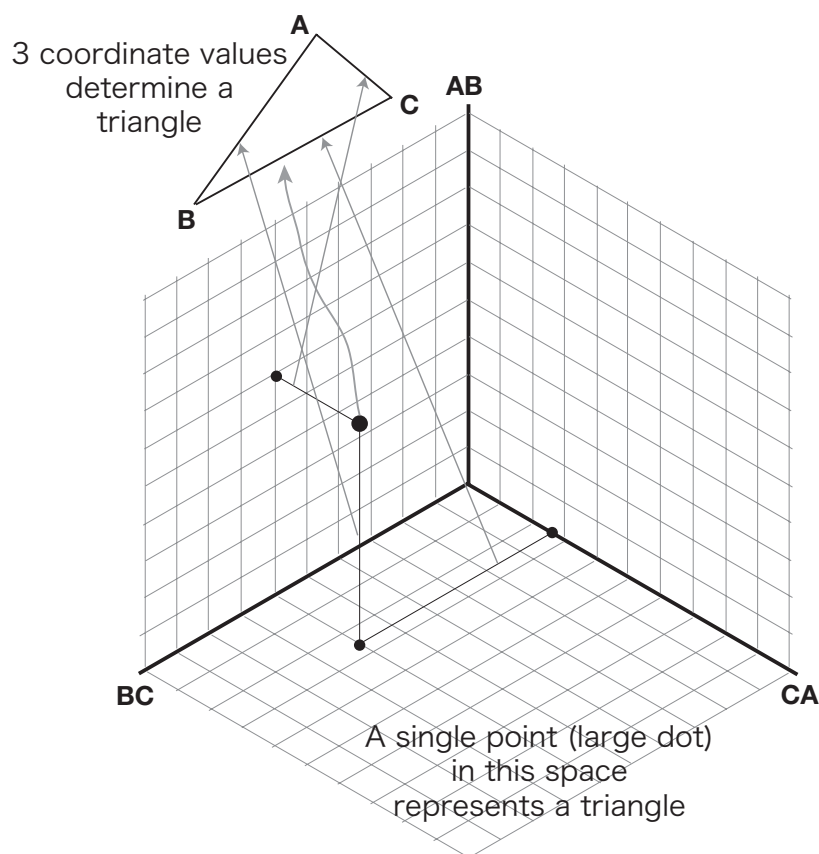

Figure 17: A Configuration Space

However, this configuration space has a redundant region, since a triangle (in Euclidean space) has a certain constraint. And if we delete this redundancy, the result is what Barbour calls *Platonia*, the arena within which this world evolves, given a law governing this world.

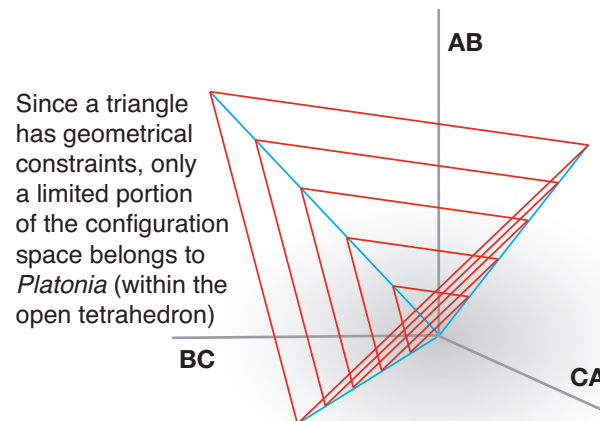

Figure 18: *Platonia* for Possible Triangles

This *Platonia* has the metric of Euclidean geometry. But we can further extract a more abstract frame where metric becomes arbitrary and only *shapes* are essential. Take any equilateral triangle (shown in red lines in the Figure) which is a cross-section of the open tetrahedron of *Platonia*. On any such triangle frame, all possible shapes of a configuration of A, B, and C can be represented. Barbour thus calls it *Shape Space*. And on this *Shape Space*, we can express the trajectory of our world (consisting of three mass points A, B, and C).

To make our model a bit more “realistic,” suppose our three points form a planetary system, B and C revolving around A, according to our classical representation, presupposing *space* in which this motion takes place. But the same motion can be represented another way, according to relationalism, such as Leibniz’s. Then, only situation counts, without external frame such as absolute space. If we take the relational view, what counts is a sequence of triangles (sometimes degenerated), as is shown in the right-hand side of the following Figure. (Although seven situations (1)-(7) are aligned on a vertical line, this is inessential, since only shapes are important.)

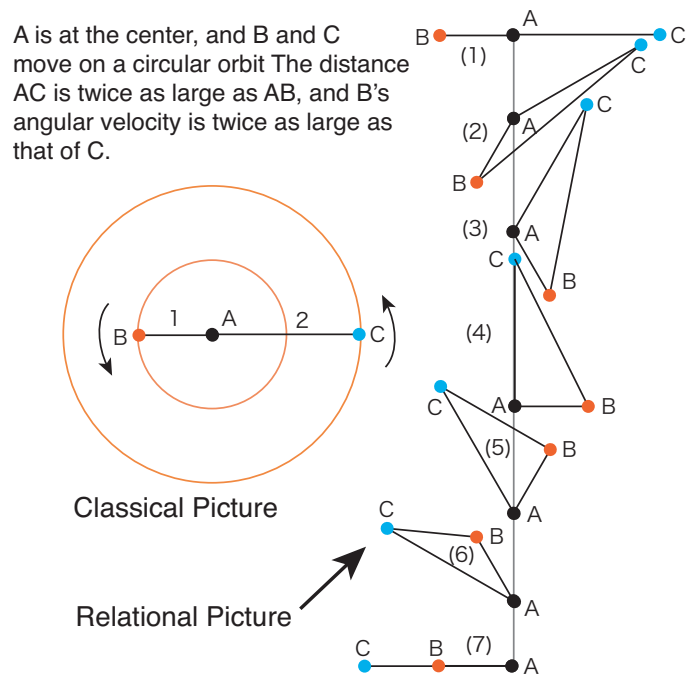

Figure 19: Two Representations of Planetary Motion

Now we ask: how can this motion be represented in *Shape Space*? The answer is very simple, as is shown in Figure 19. Since metric is arbitrary in *Shape Space*, only qualitative information is represented. And further notice time axis exists neither in *Platonica* nor in *Shape Space*!

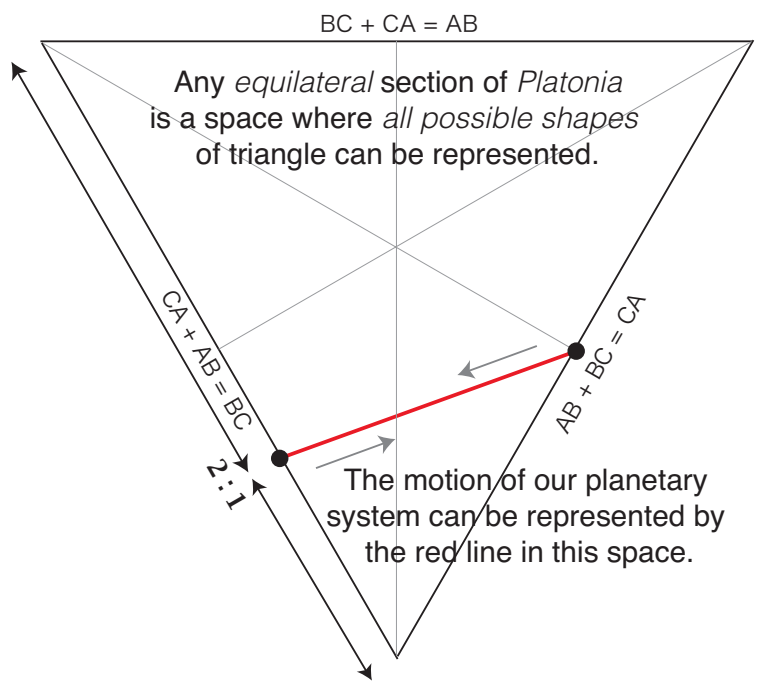

Figure 20: *Shape Space* and the Planetary Motion

From these four Figures, the reader may see a close affinity of Barbour's approach with Leibniz's geometry and dynamics. I may even suggest to replace "Shape Space" by another word *Leibniziana*, in honor of our philosopher, since many tenets of his philosophy are realized in it. For example, in addition to nonexistence of time, qualitative (and not quantitative) representations, identity of indiscernibles (right-handedness and left-handedness are regarded as the same), series of changes without time, etc.

Thus, although our model of planetary motion is a toy-model, it can nicely illustrate how a possible history of situation of the whole phenomenal world can be represented in a similar way. Once Leibniz has introduced the notion of the *path* of a moving point, it is *bound* to lead to the path of the whole situation, the trajectory of the world. I have simply pointed out this consequence from Leibniz's innovation, and added nothing to his innovation. Thus I can confidently claim that Leibniz could have done this way, if he had lived a bit longer. In the actual course of the history of science, Leibniz's manuscripts were long under seal of secrecy, and not accessible to most scholars. Thus, later people, such as Ernst Mach, had to work out their own ideas anew. I was once very much surprised by finding out that Mach, in his famous book *The Science of Mechanics*, does not refer to Leibniz's view on space and time. This is the more unfortunate, because their views have many things in common.

(To be continued to Part 3)

Bibliography

- Adams, R. M. (1994) *Leibniz: Determinist, Theist, Idealist*, Oxford University Press, 1994.
- Aiton, E. J. (1985) *Leibniz, a Biography*, Adam Hilger, 1985.
- Alexander, H. G., ed. (1956) *The Leibniz-Clarke Correspondence*, Manchester University Press, 1956.
- Ariew, R., and Garber, D., tr. and ed. (1989) *G. W. Leibniz Philosophical Essays*, Hackett, 1989.
- Arthur, R. T. W. (1985) "Leibniz's Theory of Time," in *The Natural Philosophy of Leibniz*, ed. by K. Okruhlik and Brown, J. R., 263-313.
- Barbour, J. B. (1995a) "Mach before Mach," in Barbour and Pfister 1995, 6-8.
- Barbour, J. B. (1995b) "General Relativity as a Perfectly Machian Theory," in Barbour and Pfister 1995, 214-236.
- Barbour, J. B. (2000) *The End of Time*, Phoenix, 2000.
- Barbour, J. B. (2001) *The Discovery of Dynamics*, Oxford University Press, 2001.
- Barbour, J. B., and Bertotti, B. (1982) "Mach's Principle and the Structure of Dynamical Theories," *Proceedings of the Royal Society London* 382: 295-306.
- Barbour, J. B., and Pfister H., eds. (1995) *Mach's Principle*, Birkhäuser, 1995.
- Bertoloni Meli, D. (1993) *Equivalence and Priority: Newton versus Leibniz*, Clarendon Press, Oxford, 1993.
- Burks, A. W., ed. (1970) *Essays on Cellular Automata*, University of Illinois Press, 1970.
- Cover, J. A. (1997) "Non-Basic Time and Reductive Strategies: Leibniz's Theory of Time," *Studies in the History and Philosophy of Science* 28 (1997), 289-318.
- Davis, M. (2011) *The Universal Computer, Turing Centenary Edition*, CRC Press, 2011.
- De Risi, Vincenzo (2007) *Geometry and Monadology: Leibniz's Analysis Situs and Philosophy of Space*, Birkhäuser, 2007.
- Earman, J. (1989) *World enough and Space-time*, MIT Press, 1989.
- Einstein, A. (1905a) "On the Electrodynamics of Moving Bodies," *Annalen der Physik* 17, reprinted in the *Collected Papers of Albert Einstein* 2, pp. 140-171.
- Einstein, A. (1905b) "Does the Inertia of a Body depend upon its Energy Content?" *Annalen der Physik* 18, reprinted in the *Collected Papers of Albert Einstein* 2, pp. 172-174.
- Einstein, A. (1952) *Relativity, the Special and the General Theory*, Three Rivers Press, 1961. (Original edition in German, 1917, and this translation is 15th ed., 1952)
- Garber, D. (1995) "Leibniz: Physics and Philosophy," in Jolley (1995), pp. 270-352.
- Garber, D. (2009) *Leibniz: Body, Substance, Monad*, Oxford University Press, 2009.
- Gerhardt, C. I., ed. [abbreviated as Gerhardt M] *Leibnizens mathematische Schriften*, 7 vols., A. Asher, 1849-1863.

- Gerhardt, C. I., ed. *Die Philosophischen Schriften von Gottfried Wilhelm Leibniz*, 7 vols., Weidmann, 1875-1890.
- Jolley, N. ed. (1995) *The Cambridge Companion to Leibniz*, Cambridge University Press, 1995.
- Lynden-Bell, D. (1995) "A Relative Newtonian Mechanics," in Barbour and Pfister 1995, 172-178.
- Loemker, L. E., tr. and ed. (1969) *Gottfried Wilhelm Leibniz, Philosophical Papers and Letters*, 2nd ed., Kluwer Academic Publishers, 1969.
- Mach, E. (1960) *The Science of Mechanics*, Open Court, 1960.
- Mates, B. (1986) *The Philosophy of Leibniz: Metaphysics and Language*, Oxford University Press, 1986.
- Rescher, N. (1991) *G. W. Leibniz's Monadology*, University of Pittsburgh Press, 1991.
- Rutherford, D. (1995a) "Metaphysics: The Late Period," in Jolley (1995), pp. 124-175.
- Rutherford, D. (1995b) *Leibniz and the Rational Order of Nature*, Cambridge University Press, 1995.
- Smith, J. E. H. (2011) *Divine Machines: Leibniz and the Sciences of Life*, Princeton University Press, 2011.
- Smith, J. E. H., and Nachtomy, O., eds. (2011) *Machines of Nature and Corporeal Substances in Leibniz*, Springer, 2011.
- Taylor, E. F., and Wheeler, J. A. (1992) *Spacetime Physics: Introduction to Special Relativity*, 2nd edition, Freeman, 1992.
- Taylor, E. F., and Wheeler, J. A. (2000) *Exploring Black Holes*, Addison Wesley Longman, 2000.
- Thatcher, J. W. (1970) "Self-Describing Turing Machines and Self-Reproducing Cellular Automata," in Burks (1970), 103-131.
- Turing, A. (1936) "On Computable Numbers, with an Application to the Entscheidungsproblem," *Proceedings of the London Mathematical Society*, ser. 2, 42 (1936), 230-267.
- Uchii, S. (1989) *Truth, Proof, and Computation: Logic and Machine* (in Japanese), Kyoto: Minerva, 1989.
- Uchii, S. (2004) *Tracing Einstein's Ideas—Introduction to the Philosophy of Space and Time* (in Japanese), Kyoto: Minerva, 2004.
- Uchii, S. (2006) *The Riddle of Space and Time* (in Japanese), Chu-ko Shinsho, 2006.
- Uchii, S. (2009) "An Informational Interpretation of Monadology," in *Logic, Methodology and Philosophy of Science, Proceedings of the 13th International Congress* (ed. by Clark Glymour, Wang Wei, and Dag Westerståhl), College Publications, 2009, pp. 344-353.
- Uchii, S. (2015a) "Leibniz's Theory of Time," PhilSci-Archive 11448
- Uchii, S. (2015b) "Monadology, Information, and Physics, Part 1: Metaphysics and Dynamics (revised)," PhilSci-Archive 11523

Vailati, E. (1997) *Leibniz and Clarke*, Oxford University Press, 1997.

Wang, H. (1957) "A Variant to Turing's Theory of Computing Machines," *Journal of the Association for Computing Machinery* 4, 1957.