

An Armstrongian Defense of Dispositional Monist Accounts of Laws of Nature

Mousa Mohammadian (mousa.mohammadian@ahduni.edu.in)

Ahmedabad University

This is a pre-print version of a forthcoming paper in the *European Journal for Philosophy of Science*.

Abstract Bird reveals an important problem at the heart of Armstrong’s theory of laws of nature: to explain how a law necessitates its corresponding regularity, Armstrong is committed to a vicious regress. In his very brief response, Armstrong gestures towards an argument that, as he admits, is more of a “speculation.” Later, Barker and Smart argue that a very similar problem threatens Bird’s dispositional monist theory of laws of nature and he is committed to a similar vicious regress. In this paper, first, I construct Armstrong’s would-be argument in response to Bird. Second, I argue that his response makes his account of laws and natural properties incompatible with science. Finally, I argue that Armstrong’s strategy to address Bird’s criticism can be used, quite ironically, to defuse Barker and Smart’s argument against Bird.

Keywords laws of nature, categorical properties, dispositional properties, instantiation of properties, D. M. Armstrong, Alexander Bird

1. Introduction

Bird (2005) reveals an important problem at the heart of Armstrong’s theory of laws of nature: to explain how a law necessitates its corresponding regularity, Armstrong is committed to a vicious regress. In his very brief *Reply to Bird* (2005), Armstrong gestures towards a response that, as he admits, is more of a “speculation” than an argument. Later, Barker and Smart (2012) argue that a very similar problem threatens Bird’s dispositional monist theory of laws of nature and he is committed to a similar vicious regress. In this paper, I construct Armstrong’s would-be argument in response to Bird. Then, I argue that his response causes more problems than it solves for his account of laws and natural properties. Finally, I show that Armstrong’s strategy to address Bird’s criticism can be used, quite ironically, to defuse Barker and Smart’s argument against Bird.

The structure of the paper is as follows. In Section 2, I provide a brief account of Armstrong's theory of natural properties and laws of nature, together with Bird's criticism of this theory. In Section 3, I discuss Armstrong's very brief *Reply to Bird* (2005) and construct his would-be argument in response to Bird's criticism. In Section 4, I show that Armstrong's response results in some important inconsistencies between his account of laws and natural properties, on the one hand, and some verdicts of our best scientific theories, on the other hand. Section 5 briefly discusses Bird's dispositional monist account of natural properties and laws of nature and Barker and Smart's (2012) critique of Bird's view. In Section 6, I argue that the strategy that was *unsuccessfully* used by Armstrong to provide a response to Bird's criticism can indeed be successfully used to defuse Barker and Smart's argument against Bird. Finally, in Section 7, I answer a possible objection against my argument.

2. Armstrong's Account of Laws of Nature and Bird's Criticism

Armstrong (1985) holds that natural properties (henceforth simply 'properties') are categorical: they lack any dispositional character or non-trivial modal force. In his view, laws of nature (or simply 'laws') are higher-order necessitation relations between properties. For example, consider the statement "a positively charged object that is located in an electric field experiences an attractive force in the direction of the field." Here, the positively charged object has three properties: "having positive charge" (F), "being located in an electric field" (G), and "experiencing a force of attraction in the direction of the field" (H). Now, according to Armstrong, the abovementioned statement indicates a law of nature if and only if there is a triadic nomic relation (N -relation) among properties F , G , and H according to which having F and G *necessitates* having H .

In Armstrong's account, laws (or N -relations between properties) have some important characteristics. First, they are *physically necessary*. Secondly, they are *metaphysically contingent*: there

are possible worlds in which properties F , G , and H exist but an object with properties F and G does not have property H . That is, there are possible worlds in which a positively charged object located in an electric field *does not* experience a force in the direction of the field. Finally, laws are themselves properties and hence categorical.

Table 1 provides an overview of properties, laws, and their relation with particulars in Armstrong’s view. Properties—denoted by upper-case letters F , G , H , etc.—and their N -relations—denoted by $N(F,G,H)$ —are in the *domain of universals*. Since $N(F,G,H)$ is a relation among three properties, it constitutes a second-order *relational* fact (or state of affairs). Then there is the *domain of particulars*: Fa and Gb denote, respectively, “object a ’s instantiating F ” and “object b ’s instantiating G .” $Reg(F,G,H)$ denotes the regularity “everything that is F and G is also H ” and is a general first-order relational fact that incorporates many specific first-order relational facts such as “ a that is F and G is also H ,” “ b that F and G is also H ,” and “ c that is F and G is also H ” and so on.

Domain of Universals	$N(F,G,H)$ $F, G, \text{ etc.}$	N -relation among properties F , G , and H (second-order relational fact) Natural properties
Domain of Particulars	$Reg(F,G,H)$ Fa, Gb	Everything that is F and G is also H (first-order relational fact) a ’s being F , b ’s being G

Table 1

According to Armstrong, a law of nature entails or necessitates its corresponding regularity. That is, $N(F,G,H)$ necessitates $Reg(F,G,H)$. For instance, the N -relation among universals or properties “being positively charged,” “being in an electric field,” and “experiencing a force in the direction of the electric field” necessitates the regularity that “every positively charged particle in an electric field bears a force in the direction of the field.” *But how exactly does a law necessitate its corresponding regularity?* Bird’s (2005) criticism is structured around this important question to which, he argues, Armstrong cannot provide a satisfactory answer. First, $N(F,G,H)$ cannot

metaphysically necessitate $Reg(F,G,H)$ because $N(F,G,H)$, as a categorical property, lacks any nontrivial modal force through which it can metaphysically necessitate anything distinct from it. But $Reg(F,G,H)$, a first-order relational fact, is clearly distinct from $N(F,G,H)$, a second-order relational fact.¹

Secondly, $N(F,G,H)$ cannot *contingently* necessitate $Reg(F,G,H)$. For this to happen, “ $N(F,G,H)$ necessitates $Reg(F,G,H)$ ” should itself be an N -relation between $N(F,G,H)$ and $Reg(F,G,H)$ —say, $N'(N,R)$ —in virtue of which $N(F,G,H)$ necessitates $Reg(F,G,H)$. But this only pushes the problem one step backward. Now we need another N -relation, N'' , say, to explain why “ $N'(N,R)$ necessitates “ $N(F,G,H)$ necessitates $Reg(F,G,H)$ ”” and so on *ad infinitum*. This constitutes a regress. In this regressing hierarchy of N -relations, the modal force of any N -relation (e.g., N') should be conferred upon it by a higher order N -relation (e.g., N'') which, in turn, requires another N -relation of an even higher order (e.g., N''') for its modal force and so on *ad infinitum*. This deprives N -relations from the modal forces that they are supposed to have in Armstrong’s account to necessitate their corresponding regularities. Thus, Bird concludes that the infinite regress is vicious.

3. Armstrong’s Strategy in Response to Bird’s Criticism

Armstrong’s *Reply to Bird* (2005) is very brief and, as he admits, more of a “speculation” rather than an argument. Here, I construct Armstrong’s would-be argument to see if it defuses Bird’s criticism. Armstrong points out that he does not change his view about the metaphysical contingency of universals including laws. This requires abandoning categorical monism which is the pillar of his metaphysical theory of universals—a view that he keeps defending in his subsequent works too (see, for instance, Armstrong 2012). However, he twice discusses a change in his *theory of instantiation of*

¹ As Lewis (1983, 366) famously writes, “ N [-relation] deserves the name of ‘necessitation’ only if, somehow, it really can enter into the requisite necessary connections. It can’t enter into them just by bearing a name, any more than one can have mighty biceps just by being called ‘Armstrong’.”

universals according to which *if* a universal exists, there *must* be instances of it omni-temporally. As he puts it, “predication (instantiation) of natural properties should be taken to be necessary rather than contingent” (Armstrong 2005, 264).

Why does Armstrong discuss the necessity of the *instantiation* of universals twice in his brief reply? It seems that he is carrying out an interesting maneuver to respond to Bird’s criticism in terms of the instantiation of universals, *especially* the instantiation of *N*-relations among properties. Let me clarify this with an example. Imagine a world in which Armstrong’s account of laws and properties is true (call it ‘A-world’). In A-world’s domain of universals, there are three universals or properties: “having positive charge” (*F*), “being located in an electric field” (*G*), “experiencing a force in the direction of the electric field” (*H*). Now, imagine that in A-world’s domain of particulars, *F* and *G* get instantiated. That is, a positively charged particle and an electric field come into existence such that the particle is located in the field. So far, it is evident that the positively charged particle does not bear a force in the direction of the electric field. That is, although it instantiates *F* and it instantiates *G*, it does not instantiate *H*. After all, these properties are categorical and thus the particle’s having properties *F* and *G* does not have any force to require its having property *H*.

Now, imagine that God adds a new universal to the A-world’s domain of universals that nomically connects *F*, *G*, and *H* together. According to this nomic relation $N(F,G,H)$, having properties *F* and *G* *necessitates* having property *H*. Does this addition to *the domain of universals* suffice for the positively charged particle in the electric field to instantiate *H* and thereby to begin experiencing a force in the direction of the electric field in *the domain of particulars*? Bird argued that it doesn’t because $N(F,G,H)$ cannot necessitate its corresponding regularity. Here comes Armstrong’s maneuver: it does if adding $N(F,G,H)$ to the domain of universals *guarantees* its instantiation in the domain of particulars. If $N(F,G,H)$ stays in the domain of universals, so to speak,

and doesn't get instantiated, there is no reason to think that its corresponding regularity can be observed in the domain of particulars. Yet, if $N(F,G,H)$ gets instantiated, then H should be instantiated too. $N(F,G,H)$, as mentioned earlier, is a second-order relational universal that establishes a nomic relation among *universals* F , G , and H . Its instantiation, thus, establishes a corresponding law-like relation among the *instantiations* of F , G , and H . According to this first-order relation, if something instantiates F and G , it should instantiate H too. Thus, in A -world, when the positively charged particle that is located in an electric field comes into existence—and thereby instantiates F and G —if $N(F,G,H)$ gets instantiated then H gets instantiated too and the positively charged particle begins to experience an attractive force in the direction of the electric field. As a result, $Reg(F,G,H)$ obtains.

Now, imagine that Armstrong can show that *whenever* F and G get instantiated, $N(F,G,H)$ gets *necessarily* instantiated too. If this happens, every object that has properties F and G should have property H too. Therefore, $Reg(F,G,H)$ obtains. This, I believe, is what Armstrong aims for in his reply to Bird. Now that Bird has successfully argued that a law cannot necessitate its corresponding regularity, Armstrong aims to show that:

- In *all* the relevant first-order facts that involve instantiation of some of the properties that are related by an N -relation, *something* necessitates the instantiation of the N -relation and thereby the instantiation of all the properties that are related by the N -relation. For instance, when F and G which are related to H through $N(F,G,H)$ get instantiated, *something* necessitates the instantiation of $N(F,G,H)$ and thereby the instantiation of H .
- This, in turn, results in a permanent *first-order* lawlike relation among the particulars that instantiate these properties.

- Therefore, a corresponding regularity relation—e.g., $Reg(F,G,H)$ —obtains among these particulars.

Call this *Armstrong's strategy*. If Armstrong were to provide a proper ground for the necessary instantiation of the N -relation, his strategy would succeed in establishing a corresponding regularity without making the problematic claim that the law necessitates the regularity. This would explain why in his very brief reply to Bird, he twice mentions *necessary instantiation of universals*.

Now, what is the ground of necessary instantiation of an N -relation? What is that “something” which necessitates the instantiation of $N(F,G,H)$ when it does exist in the domain of universals? In response to this question, Armstrong invokes his *principle of instantiation*: every genuine universal is *necessarily* instantiated “omni-temporally” (2005, 264) and uninstantiated universals are “illegitimate abstractions” (2004, 144). Therefore, in A -world with a positively charged particle in an electric field, if $N(F,G,H)$ really exists then according to the principle of instantiation, it must be instantiated. This, in turn, results in instantiation of H —hence, $Reg(F,G,H)$ obtains.

4. Problems with Armstrong's Response

Unfortunately, Armstrong's strategy doesn't work. In general, many believe that a viable metaphysical theory of natural properties and laws of nature should be compatible with our best science. If according to our best science something is a law of nature or a natural property, it should also be a law of nature or a natural property according to our metaphysical theory. In other words, our metaphysical theory should never jettison actual scientific laws or natural properties as, say, “illegitimate abstractions” for the sake of a more coherent metaphysical narrative.² This approach is accepted by Armstrong who believes in what he calls “*a posteriori* Realism” about universals: what

² This, obviously, does not mean that we can never revise (even) our best scientific theories and most well-established laws of nature. The point is that an inconsistency between a well-established law and one's *metaphysical* theory of laws is hardly a proper reason for such a revision.

properties and N -relation are in the world “is to be decided *a posteriori*, on the basis of total science” (1985, 83). Yet, as I argue, his principle of instantiation has consequences that are in clear conflict with this approach.³

Armstrong suggests that a genuine natural property should have some instances “omni-temporally” (2005, 264). It is quite clear that by “omni-temporally” he doesn’t mean at every moment of time. In other words, Armstrong does not adopt a strong version of the principle of instantiation according to which every universal should have an instance at every moment of time. The trouble with this is quite obvious. We have good scientific reason to think that some scientifically well-established natural properties are not instantiated at all times. For example, the property of having the atomic number 117 is the defining property of tennessine (Ts), a synthetic chemical element produced in 2010 for the first time. This highly unstable atom has two isotopes: ²⁹⁴Ts with a half-life of fifty milliseconds and ²⁹³Ts with a half-life of twenty milliseconds. Having such a property instantiated permanently would mean having tennessine in the world continuously. But our best scientific theories indicate that it is near to impossible to naturally achieve the laboratory conditions under which tennessine is produced synthetically. So whenever tennessine is not being produced by scientists in their laboratories, there is no reason to think that this element exists. Therefore, there is no reason to think that the property of having atomic number 117 is omni-temporally instantiated.

So Armstrong adopts a weaker version of the principle of instantiation, consistent with his four-dimensionalist or eternalist view of time, and says that a universal just needs to be instantiated *at some time or other*. Yet, he still runs into trouble. The first problem can be called “the problem of the right time and the right place.” Imagine that $N(F,G,H)$ exists and a particular object instantiates

³ Here, I primarily focus on the scientific ramifications of Armstrong’s principle of instantiation. For a discussion on its metaphysical problems, see (Moreland 2001, chap. 6).

F and G at two different moments of time t_1 and t_2 . However, $N(F,G,H)$ —and thereby H —only gets instantiated at t_2 . The principle of instantiation is satisfied but, clearly, $Reg(F,G,H)$ doesn't obtain. Similarly, imagine that F and G are instantiated by two objects, o_1 and o_2 but only o_1 instantiates $N(F,G,H)$. Therefore, only o_1 instantiates H . Again, the principle of instantiation is satisfied and $N(F,G,H)$ is instantiated but $Reg(F,G,H)$ doesn't obtain. The principle of instantiation, at least definitely its weak version, is too weak to guarantee the instantiation of $N(F,G,H)$ *at the right time and in the right place*.

Secondly, there are some genuine scientific laws that have never been instantiated even though they aren't in principle vacuous laws. For instance, it is a law that a sphere made of californium-251 with a mass of more than five kilograms explodes as a result of a chain reaction. For, five kilograms is the critical mass of californium-251 which is the minimum amount of fissionable material needed to maintain a nuclear chain reaction. Unlike some (in principle) vacuous laws, such as Newton's first law whose instantiation requires a body that is not under the influence of any force and hence is physically impossible, this law is *contingently* uninstantiated because we have never had a sphere made of californium-251 with a mass of more than five kilograms. We know this because californium is a synthetic element and our best physical and cosmological theories indicate that it is not generated naturally let alone in volumes that can reach its critical mass. Therefore, this law remains an "illegitimate abstraction" unless we have an explosion of a californium Atomic Bomb in the future. But, first, we have no reason to believe that this event will happen. Secondly, it is quite clear that the *scientific* status of this law and its role in scientific practice is independent of whether such an event will occur in the future or not.⁴

⁴ It might be suggested that "a sphere made of californium-251 with a mass of more than five kilograms explodes as a result of a chain reaction" is reducible to some *instantiated* fundamental law(s) governing the interactions of subatomic particles and the atomic nucleus. And this makes the

To sum up, Armstrong's principle of instantiation entails that some obviously scientific laws and natural properties are illegitimate abstractions. Because of this principle, Armstrong's metaphysical theory falls out of the frying pan of Bird's criticism into the fire of incompatibility with science.

5. Bird's Account of Laws of Nature and Its Criticism

Bird (2007) holds that *all* properties⁵ are *essentially* dispositional: the essence of every property is a disposition to manifest some characteristic response to a certain kind of stimulus. For instance, the essence of the dispositional property of "fragility" is manifesting the property of "breaking" as a *response* to the *stimulus* property of "being under stress." Let's call this Stimulus–Response relation that determines the essence of a property an 'SR-relation'. In Bird's view, laws are identified by SR-

uninstantiated status of the law governing the critical mass of californium-251 unproblematic. This is a *scientifically* substantial claim that can be accepted only if one shows that this alleged reduction can be really done in a theoretically acceptable manner. I am not aware of any such reduction. In fact, from different models that have been developed for calculating the critical mass of fissionable elements in nuclear physics, one gets a strong impression that such a reduction is by no means readily available. Nuclear fission occurs when a nucleus is struck by a neutron. This process results in releasing energy and emitting other neutrons which, in turn, can bring about more fissions. Now, imagine a sample of a radioactive material that emits neutrons. These released neutrons can be divided into three groups: (i) neutrons that reach the surface of the fissionable material sample and escape, (ii) neutrons that strike nuclei and cause fissions, and (iii) neutrons that strike nuclei but scatter from them without causing fissions. To have a chain reaction, we need a large enough sample—i.e., a sample that reaches the critical mass—in which "the number of neutrons that do not escape is just high enough to induce fission in all nuclei" (Reed 1996, 162). In calculating the critical mass of uranium-235, if we don't take group (iii) into account—in other words, if we assume that all the "scattered" neutrons are "scaped" neutrons—the final result is about twice the real critical mass of uranium-235. This shows that in calculating the critical mass, we must take "scattered" neutrons into account. For this reason, we should take into account the average distance that these scatterings travel within the sample (Reed 1996, 163). This average distance, however, is a function of the *shape* of the sample. Thus, the critical mass of a fissionable element changes depending on, say, whether it is spherical or cylindrical. Since shape plays a crucial role in the models suggested for calculating the critical mass—besides Reed (1996), see also Serber (1992) and Derrington (1990)—it seems quite unlikely that we can easily "reduce" the laws governing the critical mass to more fundamental laws in which, presumably, the shape of the sample cannot play a role.

⁵ Bird focuses on *fundamental* natural properties and *fundamental* laws of nature (2007, chap. 3). For the sake of brevity, I omit fundamentality here.

relations. Since a property's *identity* is determined by its SR-relations with other properties and never changes across different possible worlds—otherwise, it wouldn't be the same property—SR-relations (or laws) are fixed across all possible worlds. That is, they are metaphysically necessary.

Table 2 shows properties, SR-relations, and their corresponding particulars and patterns of behavior as described in Bird's account. In the domain of universals, we have properties and their SR-relations. Upper-case letters D , S , and R respectively denote dispositional, stimulus, and response properties—e.g., “fragility,” “being under stress,” and “breaking.” $SR[D,S,R]$ denotes the SR-relation among D , S , and R according to which dispositional property D essentially is (or consists in) manifesting property R in response to property S —e.g., fragility consists in manifesting breaking (or a tendency to break) in response to being under stress. SR-relations are laws of nature and constitute second-order relations. Then there is the domain of particulars. Lower-case letters d , s , and r denote particulars that instantiate properties D , S , and R —e.g., “a fragile vase,” “a vase under stress,” and “a broken vase.” $Reg[D,S,R]$ denotes a regularity relation (or a pattern of tendency) among particulars with properties D , S , and R —e.g., “All fragile vases are breaking (or tend to break) under stress.” Such regularities or patterns of tendency constitute first-order relational facts.

Domain of Universals	$SR[D,S,R]$	SR-relation among properties D , S , and R (second-order relational fact)
	D, S, R	Properties (disposition, stimulus, and response)
Domain of Particulars	$Reg[D,S,R]$	Regularity relation among particulars that instantiate D , S , and R (first-order relational fact)
	d, s, r	Particulars that instantiate properties D , S , and R

Table 2

According to Barker and Smart (2012), Bird's theory of laws is vulnerable to the same problem that he raises against Armstrong. For, in Bird's account too, there is an alleged necessary relationship between a law of nature and its corresponding regularity (or patterns of tendency). That

is, $SR[D,S,R]$ necessitates $Reg[D,S,R]$. For instance, the SR -relation among properties “fragility,” “being under stress,” and “breaking,” necessitates “All fragile vases are breaking (or tend to break) under stress.” Barker and Smart ask how does a second-order relational fact (or a law of nature) necessitate its corresponding first-order regularity? That is, in virtue of what does $SR[D,S,R]$ necessitate “All fragile vases break under stress”? It seems that Bird’s only option is to consider a higher-order SR -relation (SR') between $SR[D,S,R]$ and $Reg[D,S,R]$ in virtue of which “ SR necessitates R .” But then we need another SR -relation (SR'') to necessitate “ SR' necessitates “ SR necessitates R ”” and so on *ad infinitum*.

6. Armstrong’s Strategy Saves Bird’s Account of Laws of Nature

I argue that there is a significant discrepancy between Armstrong’s and Bird’s accounts of laws which immunizes Bird’s to the problem of vicious regress. Ironically, for this reason, I rely on a slightly modified version of Armstrong’s strategy.

Imagine a world in which Bird’s account of properties and laws is true (call it “ B -world”). There are three universals in this world: “having positive charge,” “being located in an electric field,” and “experiencing a force in the direction of the electric field.” Since Bird is a dispositional monist, these properties should be dispositions. Let’s *assume* that according to the dispositional structure of the B -world—more on this assumption soon—the property “having positive charge” is a disposition (D) to manifest the property “experiencing a force in the direction of the electric field” as the response (R) to the stimulus property (S) of “being located in an electric field.” This simply means that there exists an SR -relation among these three properties. Therefore, in B -world too, it is a law of

nature that positively charged objects that are located in an electric field bear a force in the direction of the field.⁶

Before going any further, I need to address an issue regarding the assumption that I just made about the dispositional structure of the *B*-world. For an advocate of Bird's metaphysical account of properties and laws, this assumption is redundant: assuming that Bird's account is true, his nomic necessitarianism entails that if the abovementioned properties *D*, *S*, and *R* exist in *any* possible world, *necessarily* they are in the *SR*-relation that I assumed they are. For this relation is fixed by the essences of these properties—that is, *D* is *essentially* a disposition to manifest *R* in response to stimulus *S* and, therefore, no other dispositional structure is possible for these properties. Ergo, the assumption is redundant. As long as we strictly adhere to Bird's metaphysical system—which is what I aim to do for the most part—this observation is correct. Thus, a brief justification for making this assumption is needed.

As we shall see, I argue that coupled with a modified version of Armstrong's strategy, Bird's dispositional essentialism can provide a convincing response to Baker and Smart's criticism. For Bird (2007, 48–49), at the very least in a “tidy” metaphysics that doesn't include two different modal classes of laws, dispositional essentialism entails nomic necessitarianism. But, for some, it ain't necessarily so. For example, Hendry and Rowbottom's *permissive* dispositional essentialism “is committed to a property's identity being tied to its dispositional profile or causal role, yet is compatible with moderate interworld variation in a property's dispositional profile” (2009, 670) and

⁶ Here, I intentionally use what can be considered a *qualitative* expression of Coulomb's law. It is a matter of dispute whether Bird's dispositional essentialism can make a good sense of the *quantitative* expression of the Coulomb's law, i.e., “ $F = -\epsilon_0(pq/r^2)$ ” where ϵ_0 is a constant, p and q are the values of two charges whose distance is r , and F is the force between the charges. This issue goes beyond the scope of my paper but suffice to say that even some of those who argue that Bird's account cannot make a good sense of quantitative laws, admit that the qualitative form of the Coulomb's law “looks amenable to dispositional essentialism” (Sartenaer, Guay, and Humphreys 2020, 10).

hence with moderate *nomic* variation in different possible worlds. By adding the abovementioned assumption about the dispositional structure of the *B*-world, my argument remains applicable to Bird's *strict* dispositional essentialism as well as Hendry and Rowbottom's permissive dispositional essentialism. In the case of the latter, we just need to take into account the dispositional profiles of relevant properties. These profiles might slightly change from one possible world to another which results in slight changes in the dispositional structure of these worlds. Hence the assumption about the dispositional structure of *B*-world.

Now, imagine that in *B*-world, a positively charged particle and an electric field come into existence such that the particle is located in the electric field. This means that the positively charged particle instantiates properties *D* and *S* because it is positively charged (it is a *d*) and it is located in an electric field (and hence it is an *s*). Now, does this mean that the positively charged particle begins to experience a force in the direction of the electric field (and thus becomes an *r*)? In other words, from the *instantiation* of properties *D* and *S*, does it follow that property *R* gets *instantiated* and hence $Reg[D,S,R]$ obtains? I argue that it does. Here is my argument.

- P1. Property *D* is (essentially and hence necessarily) manifesting property *R* in response to property *S*.
- C1. Instantiating property *D* is (essentially and hence necessarily) instantiating property *R* in response to instantiation of property *S*.
- P2. The particle instantiates *D* and instantiates *S*.
- C2. The particle instantiates *R*.
- C3. $Reg[D,S,R]$ obtains.

In this argument, *P1* is just an articulation of the dispositional nature of *D*, *S*, and *R*, captured by $SR[D,S,R]$. *C1*, as I argue, follows from *P1*. *P2* is an assumption. *C2* follows from *C1* and *P2*. Finally, *C3* follows from *P2* and *C2*.

Probably the most crucial step in this argument is inferring *C1* from *P1*. This inference is justified for three reasons. First, an instantiation of a property carries the essential attributes or characteristics of the property. This seems quite uncontroversial. For instance, if something instantiates the property of fragility, it should have the essential characteristics of fragility. If it doesn't, then there is no reason to think that it instantiates the property of fragility. The essential characteristic of *D* is fully captured by $SR[D,S,R]$ and is stated by *P1*—assuming that $SR[D,S,R]$ is the only *SR*-relation in which *D* enters. So “instantiating property *D*” just is “having the essential characteristics of property *D*” which is, according to *P1*, *manifesting* property *R* in response to having of property *S*. But ‘having a property’ or ‘manifesting a property’ are just synonyms of ‘instantiating a property’. Thus, instantiating property *D* is (essentially and hence necessarily) instantiating property *R* in response to instantiation of property *S*.

Second, the fact that *P1* pertains to the realm of universals but *C1* pertains to the realm of particulars cannot be used against inferring the latter from the former. This inference is warranted in virtue of the dispositional nature of the properties that are mentioned in *P1*. If one adopts categorical monism, the corresponding inference doesn't follow. For Armstrong, for instance, form

P'1. Property *F* is connected to property *G* and property *H* via property $N(F,G,H)$.

it does not follow that

C'1. Instantiating property *F* and instantiating property *G* results in instantiation of property *H*.

To bridge the gap here, Armstrong suggests that something, namely, the principle of instantiation, necessitates the instantiation of $N(F,G,H)$. But I argued that strategy doesn't work.

The fact that the distinction between categorical vs. dispositional *universals* have major ramifications for how they get *instantiated* in the domain of *particulars* is quite obvious and well-attested. As Loewer (2012, 116) explains, for instance, “instantiation [of a categorical property] in a region of space time don't [*sic*] metaphysically necessitate anything about property instantiations in wholly distinct regions.” Yet, if a dispositional property “is instantiated in a region some other properties are instantiated in distinct regions. [...] For example, gravitational mass instantiated in region R has the nature of producing an attractive force field in distinct regions.” Although Loewer's focus is on what might happen in distinct regions of space–time as a result of the instantiations of categorical vs. dispositional properties, the idea can be easily applied to what happens in *A*-world vs. *B*-world. In *A*-world, the instantiation of properties “having positive charge” and “being located in an electric field” has nothing to do with the instantiation of the separate property “experiencing a force in the direction of the electric field.” In *B*-world, however, in virtue of their dispositional nature captured by their *SR*-relation, the particular that instantiates *D* and *S* carries the modal forces of properties *D* and *S* which results in the instantiation of *R*.

Thirdly, there is a significant discrepancy between how an *SR*-relation (e.g., the one that is articulated by *PI*) and an *N*-relation hold in the realm of universals. It lies in an important difference between *SR*-relations and *N*-relations. An *SR*-relation is an *internal* relation that supervenes on the intrinsic nature of its relata and holds in every possible world containing these properties⁷ (D. Lewis 1986, 62; Armstrong 1989, 43). An *N*-relation, however, is an *external* relation (Armstrong 1985,

⁷ Or, if one adopts Hendry and Rowbottom's (2009) permissive dispositional essentialism, the same *SR*-relation holds in every possible world that contains properties with similar actual dispositional profiles.

84). It is metaphysically contingent and has nothing to do with the intrinsic nature of its relata. In fact, categorical properties cannot, by definition, intrinsically necessitate such non-trivial relations.

Now, let's suppose someone accepts *PI* but rejects *CI*. This results in an inconsistency in one's metaphysical commitments which, in turn, brings about an absurdity in one's theory of instantiation. Imagine that *PI* is true and it indicates an internal relation between *D*, *S*, and *R*. Now, imagine that God creates *D* and *S* in the realm of universals. Moreover, imagine that God wills to relate *D* and *S* via the internal relation indicated by *PI*. It is obviously impossible to draw this relation without first creating *R*. In other words, if the internal relation expressed by *PI* is to exist in the realm of universal, property *R* should necessarily exist too. But if one rejects *CI* by saying that *instantiating* property *D* does not require *instantiation* of *R* when *S* is also *instantiated*, they commit to an internal relation among some properties in the realm of universals but deny committing to this relation among the instantiations of the properties in the realm of particulars. This inconsistency in one's metaphysical commitments requires justification. The burden of proof is on those who accept *PI* and deny *CI*. Moreover, I think that success in providing such a justification is very unlikely. Since the internal relation between properties is *constitutive of their essences*, accepting *PI* and rejecting *CI* can only be done if one thinks that through instantiation, the essences of properties change. This seems absurd to me. It is not surprising that Barker (2009, 247) admits that the "SR[-relation] is no increase-in-being over its relata in the sense that if its relata, the natural properties, exist, its *instantiation* by them must exist" (my emphasis). In other words, if some properties are in an internal relation in the realm of universals, their instantiations in the realm of particulars should be in the same relation.

If my arguments are sound, *CI* can be inferred from *PI*. Thus, if the internal relation $SR[D,S,R]$ exists, *given the instantiation* of *D* and *S*, *R* gets instantiated too and hence $Reg[D,S,R]$

obtains. Now let's go back to Armstrong's strategy and see how it helps Bird to resolve the problem of infinite regress raised by Barker and Smart. This is a slightly modified version of Armstrong's strategy that Bird can use:

- In *all* the relevant first-order facts that involve instantiation of properties D and S —which are connected to property R via the internal $SR[D,S,R]$ —*something* guarantees the instantiation of R .
- This, in turn, results in a *first-order* lawlike relation (or pattern of tendency) among the particulars that instantiate these properties.
- Therefore, a corresponding regularity relation (or pattern of tendency) is attained among these particulars (i.e., $Reg[D,S,R]$).

Now we are in a position to answer Barker and Smart's (2012, 270) question for Bird. They ask "in virtue of what does this necessitation between the second-order [relational] fact [i.e., the SR -relation,] and the first-order patterns of tendency hold?" In other words, given $SR[D,S,R]$, what does guarantee $Reg[D,S,R]$? What is this "something" that guarantees the instantiation of R ? My abovementioned argument provides the answer: given $SR[D,S,R]$ (i.e., given $P1$ is true), the instantiation of D and S by a particular ($P2$) suffice to guarantee the instantiation of R and thereby $Reg[D,S,R]$ obtains.

If my argument is sound, then it also becomes clear why Bird's account is not challenged by the problem of the right time and the right place. $Reg[D,S,R]$ obtains whenever and wherever $SR[D,S,R]$ holds (i.e., $P1$ is true) and D and S are instantiated (i.e., $P2$ is true).

7. An Objection and a Reply

An objection to my argument can be raised here.⁸ Instantiation of D and S play a significant role in my argument ($P2$). But, for instance, in my discussion of B -world, I simply stipulated the instantiation of the properties “having positive charge” and “being located in an electric field” in the B -world. But dispositional properties don’t get instantiated by stipulation. Rather, each instantiation of a property is always a response to the instantiation of a dispositional property and a stimulus property. A positively charged object can come about if, for instance, another object—e.g., a hydrogen atom—has a disposition to lose an electron in response to some stimulus—e.g., being located in a very strong magnetic field. Thus, the instantiation of property P (p) is always a response (r_i) to the instantiation of a disposition and a stimulus (d_i and s_i , respectively). But d_i , in turn, is a response (r_{i-1}) to d_{i-1} and s_{i-1} , d_{i-1} is a response (r_{i-2}) to d_{i-2} and s_{i-2} , and so on (see Figure 1).⁹ Because of the dispositional character of all properties, r_i ’s existence requires the existence of r_{i-1} which, in turn, requires the existence of r_{i-1} , and so on *ad infinitum*. Since Bird is a dispositional monist, there is no property whose instantiation can stop this regress by not requiring a preceding instantiation of a disposition and a stimulus. As a result, we have an infinite regress of instantiations in which the existence of each one requires the existence of the previous one and hence the regress is vicious. Therefore, in B -world, although the instantiation of the properties necessitates the instantiation of their SR -relation, the properties can never get instantiated. Thus, clearly, they cannot entail the instantiation of their SR -relation either.

⁸ Thanks to [REMOVED] for raising this objection.

⁹ A stimulus property is also dispositional and hence its instantiation requires the instantiation of a preceding disposition and stimulus. In Figure 1, for the sake of brevity, I overlook the stimulus properties’ “chain” of instantiation.

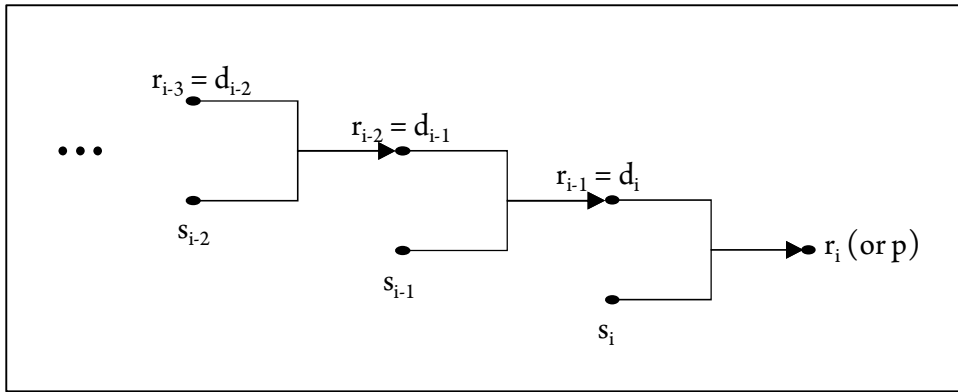

Figure 1

The issue with this objection is that this regress is not really infinite. The key point here is that the regress is in the domain of particulars because it pertains to the *instantiations* of properties. Within the domain of universals, we can have the network of all properties and their SR-relations all at once without any problem—especially since Bird is open to a platonic view of universals. How does this help? Since this is a regress of particulars, we just need to go back enough in time until we reach what is commonly known by cosmologists as “the initial state of the universe.” At that point, the regress stops because presumably no particular exists before the *initial* state of the universe.

But it might be asked that how does a property get instantiated at the initial state of the universe? In other words, how does a particular manifest a response property at the initial states of the universe, when there are no previous instantiations of a dispositional property and a stimulus property? Before discussing this question, it should be mentioned that a very close variation of it can be asked of Armstrong too. Armstrong (1997, 105) holds that there should be a nomic relation between past and future temporal parts of particulars such that at each point in time, the properties that a particular instantiates are specified by its previous properties and the *N*-relations in which they enter. But, presumably, this chain of nomic relations stops at the initial state of the universe. That is, in the history of every particular, we reach a point at which the properties of the particular are not

specified by the *N*-relations that connect them with the properties of what comes at the previous moment because there is no previous moment.

Therefore, “How do particulars at the initial state of the universe have the properties they have without being connected through law-like relations to a previous state of affairs?” is not just a question for Bird, but for Armstrong too. But this question is not as challenging as it might seem to be at the first sight. The key here is this: by asking this question, one demands an *explanation* for the properties of the particulars at the initial state of the universe. But it is not clear that such a demand is even reasonable. Consider, for instance, a specific property of the universe at its initial state, namely, very low entropy of the universe at its initial state. Why does the universe have such a very low entropy at its initial state? Some argue that even demanding such an explanation is problematic. For example, according to Sklar (1993, 311), by seeking such an explanation “we have obviously entered a problematic methodological area replete with pitfalls for the unwary.” Similarly, Callender (2004b; 2004a) argues that the initial state of the universe does not need an explanation.¹⁰ According to him, initial conditions “are the boundary of spacetime”: no condition exists before them. “If explaining initial [...] conditions entails describing what happened at a state that doesn’t exist, this strikes me as a big problem” (2004b, 198). According to these philosophers, we can reasonably think that it is just a brute fact, a fact in no need of explanation, that the universe has a very low entropy at its initial state. By adopting this approach, a similar claim can be made about all the properties that are instantiated at the initial state of the universe: the fact that these properties are instantiated at the initial state is just a brute fact and in need of no further explanation.

¹⁰ cf. Price (2004)

References

- Armstrong, D. M. 1985. *What Is a Law of Nature?* Cambridge: Cambridge University Press.
- . 1989. *Universals: An Opinionated Introduction*. Boulder: Westview Press.
- . 1997. *A World of States of Affairs*. Cambridge: Cambridge University Press.
- . 2004. “How Do Particulars Stand to Universals?” In *Oxford Studies in Metaphysics*, edited by Dean Zimmerman, 139–53. Oxford: Oxford University Press.
- . 2005. “Reply to Bird.” *Analysis* 65 (287): 264–65.
- . 2012. “Defending Categoricalism.” In *Properties, Powers, and Structures: Issues in the Metaphysics of Realism*, edited by Alexander Bird, Brian David Ellis, and Howard Sankey, 27–33. New York: Routledge.
- Barker, Stephen. 2009. “Dispositional Monism, Relational Constitution and Quiddities.” *Analysis* 69 (2): 242–50.
- Barker, Stephen, and Ben Smart. 2012. “The Ultimate Argument against Dispositional Monist Accounts of Laws.” *Analysis* 72 (4): 714–22.
- Bird, Alexander. 2005. “The Ultimate Argument against Armstrong’s Contingent Necessitation View of Laws.” *Analysis* 65 (286): 147–55.
- . 2007. *Nature’s Metaphysics: Laws and Properties*. Oxford: Oxford University Press.
- Callender, Craig. 2004a. “There Is No Puzzle About the Low Entropy Past.” In *Contemporary Debates in Philosophy of Science*, edited by Christopher Hitchcock, 240–55. Oxford: Blackwell.
- . 2004b. “Measures, Explanations and the Past: Should ‘Special’ Initial Conditions Be Explained?” *The British Journal for the Philosophy of Science* 55 (2): 195–217.
<https://doi.org/10.1093/bjps/55.2.195>.
- Derrington, Edward. 1990. “Estimate of the Critical Mass of a Fissionable Isotope.” *American Journal of Physics* 58 (4): 363–64. <https://doi.org/10.1119/1.16172>.
- Hendry, Robin Findlay, and Darrell P. Rowbottom. 2009. “Dispositional Essentialism and the Necessity of Laws.” *Analysis* 69 (4): 668–77. <https://doi.org/10.1093/analys/anp093>.
- Lewis, David. 1983. “New Work for a Theory of Universals.” *Australasian Journal of Philosophy* 61 (4): 343–77. <https://doi.org/10.1080/00048408312341131>.
- . 1986. *On the Plurality of Worlds*. Malden, MA: Blackwell Publishers.
- Loewer, Barry. 2012. “Two Accounts of Laws and Time.” *Philosophical Studies* 160 (1): 115–37.
<https://doi.org/10.1007/s11098-012-9911-x>.
- Moreland, James Porter. 2001. *Universals*. Chesham: Acumen.
- Price, Huw. 2004. “On the Origins of the Arrow of Time: Why There Is Still a Puzzle about the Low-Entropy Past.” In *Contemporary Debates in Philosophy of Science*, edited by Christopher Hitchcock, 219–39. Oxford: Blackwell.
- Reed, B. Cameron. 1996. “Estimating the Critical Mass of a Fissionable Isotope.” *Journal of Chemical Education* 73 (2): 162. <https://doi.org/10.1021/ed073p162>.
- Sartenaer, Olivier, Alexandre Guay, and Paul Humphreys. 2020. “What Price Changing Laws of Nature?” *European Journal for Philosophy of Science* 11 (1): 12.
<https://doi.org/10.1007/s13194-020-00327-4>.
- Serber, Robert. 1992. *The Los Alamos Primer: The First Lectures on How to Build an Atomic Bomb*. Berkeley: University of California Press.
- Sklar, Lawrence. 1993. *Physics and Chance: Philosophical Issues in the Foundations of Statistical Mechanics*. Cambridge: Cambridge University Press.